

Final Report by Fluorescent Lighting Fixtures Criteria
Standard Subcommittee, Energy Efficiency Standards
Subcommittee of the Advisory Committee on Energy

The subcommittee deliberated on the criteria of manufacturers or importers (manufacturers) of fluorescent lighting fixtures about energy consumption efficiency of fluorescent lighting fixtures, and summarized as follows.

1. Scope of application

Lighting fixtures which equip fluorescent lamps as the main light source. However, the following types are excluded from this application: explosion-proof types, heat resistant types, dustproof types, corrosion-resistant types, types designed for vehicles and other transport vehicles, fluorescent lighting fixtures using fluorescent lamp with less than type 40 (except fluorescent lighting fixtures specified in JIS C 8115 “Fluorescent lighting fixtures for home” and JIS C 8112 “Fluorescent lamp desk stand (for study and reading)”).
(See Attachment 1)

2. Items of Standard Criteria for Manufacturers

(1) Target fiscal year: 2005

(2) Target standard value

Concerning the fluorescent lighting fixture to be shipped domestically in the target fiscal year by the manufacturers, energy efficiency measured in (3) shall be weighted by the shipped quantity of each manufacturer in each segment in the following table, so that the harmonic average values may not fall below the target standard values. (See Attachment 2)

Segmentation			Target standard value lm/W	
Striplight type	Type 110 rapid start type fluorescent lamp		79.0	
	Type 40	Striplight lamp for high frequency lighting	86.5	
		Rapid start type fluorescent lamp	71.0	
		Starter type fluorescent lamp	60.5	
	Type 20	Starter type fluorescent lamp	Electronic ballast method	77.0
			Magnetic ballast method	49.0
Circular type	Fluorescent lamp exceeding 72 in total sum of lamp size classification		81.0	
	Fluorescent lamp exceeding 62 and 72 or less in total sum of lamp size classification		82.0	
	Fluorescent lamp with 62 or less in total sum of lamp size classification	Electronic ballast method	75.5	
		Magnetic ballast method	59.0	
Desk top stand	Compact type fluorescent lamp		62.5	
	Striplight lamp		61.5	

(Note) “lamp size classification” means the size classification specified in the appendix table 1 of JIS C 7601. Furthermore, there is no unit.

(References) lm (lumen): This is the luminous flux unit in the International System of Units. This indicates the magnitude of luminous flux discharged into the pyramid of solid angle 1 sr (steradian) from the point light source having luminous intensity of 1 cd (candela) equal to all directions.

(3) Measuring method

- 1) Energy efficiency is indicated by “lm/W” (Read as lumen per watt).
- 2) The energy efficiency shall be the numerical value obtained from dividing all luminous flux (lm) of a fluorescent lamp installed to a fluorescent lighting fixture by power consumption (W) of the fluorescent lighting fixture. (See Attachment 3)

$$\text{Energy efficiency (lm/W)} = \frac{\text{All luminous flux (lm) of the fluorescent lamp installed to a fluorescent lighting fixture}}{\text{Power consumption (W) of the fluorescent lighting fixture}}$$

(4) Display items

- 1) Display items shall be as follows.
 - Product name or model name of fluorescent lighting fixtures
 - Types of fluorescent lamps
 - All luminous flux
 - Power consumption
 - Energy efficiency
 - Name or appellation of manufacturers
- 2) The display unit of energy efficiency shall be lm/W, and its numerical value is indicated up to the first decimal place.
- 3) Display of the displayed items is described in a catalog. However, as to the desk top stand, it is displayed based on Household Goods Labeling Law.

3. Recommendations for energy-saving

(1) Efforts to be made by Users

- 1) In using the lighting fixture, users shall make efforts to select high energy efficient fixtures with all luminous flux being appropriate taking the purposes of illumination into account.
- 2) Users shall make efforts to convert incandescent lamps to fluorescent lamp fixtures wherever possible, and to attempt for energy saving by means of introducing electronic ballast (inverter) type fixture which is more excellent in quantity of light and energy efficiency in comparison with magnetic ballast type fixtures, and high frequency light-up dedicated fixture (Hf fluorescent lamp fixture).
- 3) Users shall try to frequently turn the light-out (dimming /reduction of lighting) in order to reduce unnecessary light-up, and if necessary, to attempt for introduction of the control system such as time schedules, utilization of daylight and human sensing.
- 4) Users take care of periodical cleaning and replacement of lamps, and make efforts to prevent a decrease of lighting efficiency from long period of use.

(2) Efforts to be made by Manufacturers

- 1) Manufacturers facilitate the technological development for energy-savings of lighting fixtures, and make efforts to develop high energy efficient lighting fixtures.
- 2) In an attempt to disseminate lighting fixtures with better energy efficiency, manufacturers shall make efforts to attempt to facilitate consumers’ understandings about these products.
- 3) Manufacturers shall attempt to disseminate the control system, such as with utilization of daylight and human sensing, and make efforts to enlighten about energy-savings through appropriate and efficient use of lighting fixtures.

- 4) Manufacturers shall attempt to facilitate understandings of consumers about the meaning of energy efficiency (lm/W)
- (3) Efforts to be made by the Government
In order to attempt for dissemination of lighting fixtures with high energy efficiency, manufacturers shall make efforts to take necessary measures for political supports and enlightenment to facilitate the understandings of users and manufacturers' efforts.
4. History of discussions
 - (1) A history of meetings of the subcommittee (See Attachment 4)
 - (2) Committee's list (See Attachment 5)

Subject Range of Fluorescent Lamp Fixtures

Lighting fixtures which equip fluorescent lamps as the main light source.

However, the following types are excluded from this application: explosion-proof types, heat resistant types, dustproof types, corrosion-resistant types, types designed for vehicles and other transport vehicles, fluorescent lighting fixtures using fluorescent lamp with less than type 40 (except fluorescent lighting fixtures specified in JIS C 8115 “Fluorescent lighting fixtures for home” and JIS C 8112 “Fluorescent lamp desk stand (for study and reading)”).

(References) comparison with the previous page (Table 1)

1. Fluorescent lamp fixtures excluded from the application

- (1) Explosion-proof types
- (2) Heat resistant types
- (3) Dust-proof types
- (4) Corrosion-resistant types
- (5) Types designed for vehicles and other transport vehicles
- (6) fluorescent lighting fixtures using fluorescent lamp with less than type 40 (except fluorescent lighting fixtures specified in JIS C 8115 “Fluorescent lighting fixtures for home” and JIS C 8112 “Fluorescent lamp desk stand (for study and reading)”)

2. Reasons for the exclusion

- (1) Since fluorescent lamp fixtures using for a special usage are special in specifications and structures, and they are limited in quantity, we exclude the following types from their application.

Type	Usage/ place for installation	Special structure
Explosion-proof types	Ones used in places where flammable gas arise	• Explosion-proof type fixtures (Specification of sealing and protecting not so as to ignite the gas)
Heat resistant types	Ones used in places where ambient temperature (always) is in particularly high temperature or low temperature. High temperature.... Power plant, boiler room, etc. Low temperature... Freezer, freezing room, etc.	• Heat resistant type fixture (Outer hull is heat resistant or cold resistant, and the lamp light-up device is the special specification.)
Dust-proof types	Ones used in places where there are much dust.	• Dust-proof device and dust-resistance device (the structure is dust proof and dust resistant, and lighting device is the special specification.)

Corrosion-resistant types	Ones used in places where corrosive gas arise.	• Corrosion-resistant, chemical resistant device (Materials and structures are corrosion-resistant, and the lighting device is the special specification.)
For transport vehicles	Ones used for vehicles	• Device for vehicles (Power supply and structures have special specification for vehicles)

(2) Less than type 40 fluorescent lamps, except fluorescent lamp desk top stand type specified in JIS C 8112 and fluorescent lamp fixtures for home specified in JIS C8115, have been used in hallway, toilet, water-heating room, etc. in addition to auxiliary (dimension fitting) use in the part which the conventional type 40 fixture can not be installed. But the use as merely dimension fitting device has been decreasing year by year along with development and dissemination of short-dimensioned and compact type fluorescent lamps with over type 40.

Also, there are many cases where they are used as lighting in the part not always used, so that the energy consumption volume rate is also low.

Furthermore, looking from technological and economical perspectives on the assumption of adoption of electronic ballast (inverter) and development of better efficient lamps as energy-savings measures, such energy-savings type products have no marketability for the following reasons.

1) Technological facets: Mounting the electronic ballast onto low W (watt) devices such as for 20W and 15W has little room of increased efficiency (approximately 1-2%) including higher harmonics measures. Since the capacity of the electronic ballast is large compared to that of the magnetic ballast, its usage and design property are impaired.

In addition, improvements for efficiency is poor and room of efficient improvements are not almost expected judging from the prototype results of efficient lamps (for example, lamps specialized for high frequency lighting).

2) Economical facets: The price of electronic ballast is approximately 10 times more or less comparing to that of magnetic type ballast, and it results in more than two-fold in price a product. Therefore, they are not produced other than the high priced special specification.

If we include these fixtures to the target, the classification setting is required to set segments for both electronic ballast type and magnetic ballast type in addition to many fluorescent lamp types. As a result, handling becomes extremely complicated.

Also, the energy-savings effects can not be largely expected comparing to burdens of the product development cost and the capital investment cost.

Handling of Incandescent Lamp Fixtures

1. Incandescent lamps have warm light color and are the high light source in reproducibility of colors. They are also characterized with having small size features and with not requiring ballast. Degree of design free is high as lighting fixtures, and they are widely used in general households, commercial buildings, etc.
On the other hand, on the principle of light emission, the energy efficiency is low of 14.2lm/W (JIS C 7501) in a general 60W type. Also, there is almost no difference of efficiency among individual fixtures, and in the future, large improvements can not be expected for the following reasons.
 - 1) Improvements by changes of filament design
Filament has a coiled structure, and the efficiency is improved as coils are winded densely. However, the accuracy of coiling is near limit, and so further improvements produce demerits such as short product life, impaired durability against vibration.
 - 2) Improvements by sealed gas and changes of sealed pressure
Substitutes of present argon gas can be expected, but any other gas which is more efficient than argon gas in the evaluation including costs have not found yet. Sealed pressure also reaches the upper limit of glass processing.
 - 3) Improvements by changes of filament materials
It is expected to increase visible radiation by heightening filament temperature with utilizing the material of high melting point. However, development of new materials can not be expected in the present technology from the viewpoint of life of material, mechanical strength and costs.
2. On the one hand, approximately 120 years have passed since incandescent lamps have been developed, and during that time, large stride of technological development can be seen in such cases as development of fluorescent lamps as light source. However, the innovative efficiency improvements of incandescent lamps can not be expected while looking at progress for last 20-30 years. From the viewpoint of energy-savings, it is rather important to attempt for working on replacing incandescent lamp fixtures with fluorescent lamp fixtures as much as possible in reviewing of our lifestyle.

Range Table of Targeted “Fluorescent Lamp Fixtures” (Table 1)

Current target range	This time’s target range
Over Type 40Fluorescent lamp fixtures for facilities	(110 rapid)
	(40 rapid)
	(40 Hf)
	(40 starter)
Fixtures less than type 40	Fixtures less than type 40
Hanging type fluorescent lamp fixtures for households (Range of JIS C 8115)	Fluorescent lamp fixtures for households (Range of revised JIS C 8115) (Circular tube fixture • Hanging/Surface mounted)
Surface mounted type fluorescent lamp fixtures for households (Range not included in JIS C 8115)	(20 starter fixtures • Hanging/ Surface mounted)
Fluorescent lamp stand	Fluorescent lamp stand

 Fixtures excluded

Furthermore, this table is imaging the composition ratio of energy consumption volume.

Comparison of Energy Consumption Volume by Groups (Table 2)
 (On the basis of shipping in Fiscal Year 1997)

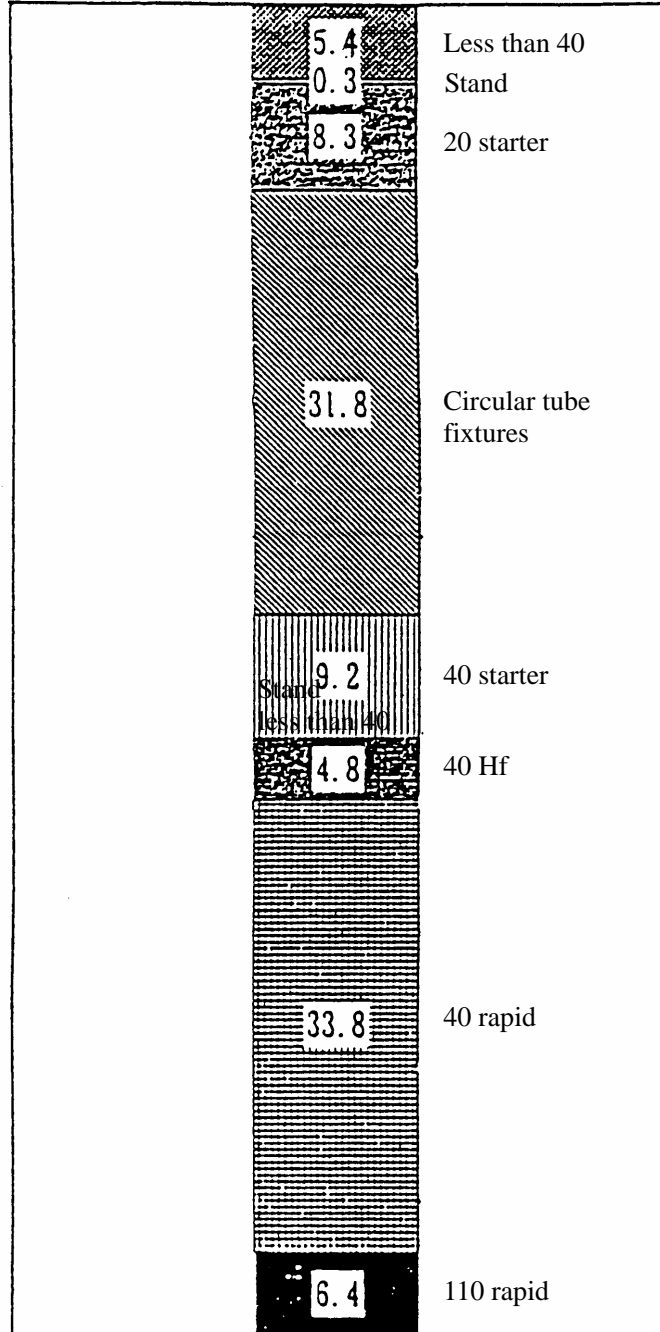

Energy consumption volume

Segmentation and Target Values

1. Segmentation

In segmentation, we focused attention on the form of lamps, output and lighting methods.

(1) Segmentation focused attention on the forms of lamps

There exist striplight types, circular types and compact types as to the form of lamps, but of this, the compact type can be said deriving from striplight lamp. Therefore, its classification setting belongs to that of striplight type. Accordingly, as to the segmentation focused attention on the form of lamps, we provided the segments of striplight types and circular types.

(2) Segmentation focused attention on output of lamps

As to the output of lamps, various outputs exist in striplight types and circular types respectively. Of this, as to striplight types, the segment of type 110, type 40 and type 20 are provided, and also as to circular types, the segments of over 72, no more than 72 over 62 and 62 or less according to the total sum of lamp size classification are provided.

(3) Segmentation focused attention on lighting method of lamps

As to striplight type 40, there exist Hf types, rapid start types and starter types depending on types of lamps and lighting methods. Since they have different efficiencies due to difference in their structures, and the consumers' needs also various, we decided it as separate segmentation considering the market situation.

In addition, as to the ballast used in the fluorescent lighting fixtures, there exist the electronic ballast type and the magnetic ballast type, but in particular, in the ballast which the total sum of lamp size classification used in striplight type 20 and circular types is 62 or less, since the electronic ballast is expensive comparing to the magnetic ballast, we classified separately because an increase portion of introduction costs associated with adoption of the electronic ballast can not be recovered by running costs.

(4) Furthermore, as to the desk top stand, we provided the segments according to the difference of lamps (compact types/ striplight types) considering the product property apart from the above-mentioned (1)- (3).

Fixtures according to the lamp types belonging to respective classification are as follows.

Segments	Fixtures belonging to classification
1) Fixtures using striplight type 110 rapid start type fluorescent lamp	<ul style="list-style-type: none"> • Fixtures using type 110 rapid starter type fluorescent lamp • Fixtures using type 96 compact type fluorescent lamp • Fixtures using compact type fluorescent lamp of type 105 for high frequency lighting only
2) Fixtures using striplight 40 type high frequency lighting dedicated striplight type fluorescent lamp	<ul style="list-style-type: none"> • Fixtures using type 40 and type 65 fluorescent lamp for high frequency lighting
3) Fixtures using striplight type 40 rapid start type fluorescent lamp	<ul style="list-style-type: none"> • Fixtures using type 40 rapid start type fluorescent lamp • Fixtures using type 36 and type 55 compact type fluorescent lamp • Fixtures using type 32, type 42 and type 45 fluorescent lamp for high frequency lighting

4) Fixtures using striplight type 40 starter type fluorescent lamp	• Fixtures using type 40 starter type fluorescent lamp										
5) Fixtures using striplight type 20 starter type fluorescent lamp and with electronic ballast type	• Fixtures using type 20 starter type fluorescent lamp and fixtures of electronic ballast type										
6) Fixtures using striplight type 20 starter type fluorescent lamp and with magnetic ballast type	• Fixtures using type 20 starter type fluorescent lamp and fixtures of magnetic ballast type										
7) Fixtures which the total sum of size classification of used circular fluorescent lamp exceeds 72	(Supplemental remarks) • ” Lamp size classification” means the size classification specified in appendix table 1 of JIS C 7601. <table border="1" style="margin-left: auto; margin-right: auto;"> <thead> <tr> <th>Size classification</th> <th>Lamp types</th> </tr> </thead> <tbody> <tr> <td>20</td> <td>FCL20/18</td> </tr> <tr> <td>30</td> <td>FCL30/28</td> </tr> <tr> <td>32</td> <td>FCL32/30</td> </tr> <tr> <td>40</td> <td>FCL40/38</td> </tr> </tbody> </table> (FCL indicates the circular starter type fluorescent lamp)	Size classification	Lamp types	20	FCL20/18	30	FCL30/28	32	FCL32/30	40	FCL40/38
Size classification		Lamp types									
20		FCL20/18									
30		FCL30/28									
32		FCL32/30									
40	FCL40/38										
8) Fixtures which the total sum of size classification of used circular fluorescent lamp exceeds 62 and no more than 72											
9) Fixtures which the total sum of size classification of used circular fluorescent lamp is 62 or less and with electronic ballast type											
10) Fixtures which the total sum of size classification of used circular fluorescent lamp is 62 or less and with magnetic ballast type											
11) Desk top stand using compact type fluorescent lamp	• Fixtures using type 27, type 18 and type 13 compact type fluorescent lamp										
12) Desk top stand using striplight type fluorescent lamp	• Fixtures using type 20, type 15 starter type fluorescent lamp										

(5) Reasons for segmentation

● Segment 1) (type 110 rapid type)

This lamp is a fluorescent lamp of high output type with tube length of 2,367mm, and it is used when obtaining high illuminance in wider space such as supermarkets, factories, etc. The tube length of the type 40 fluorescent lamp has 1,198mm, and since there is no compatibility with the type 110 fluorescent lamp, the segments shall be separated.

● Segments 2)3)4) (Striplight type 40)

These classifications are lighting fixtures having used the same size fluorescent lamps, but the used lamp types are different, and its property becomes different in the following.

Types of fluorescent lamp	Starting principles	Characteristics	Defects
Fluorescent lamp for high frequency lighting	The lamp lights up in one second or so applying high voltage between poles as well as preheating of electrode by the dedicated electronic ballast (Inverter) with lamp for high frequency lighting.	Energy efficiency is good due to high frequency lighting.	(1) It can be only used in dedicated lighting fixtures (2) Expensive comparing to the rapid method
Rapid starter type fluorescent lamp	This is the start auxiliary conductor attached lamp on the internal surface or external surface of the glass tube, and the lamp lights up in one second or so applying high voltage between poles as well as preheating of electrode.	It becomes widely spread as lighting fixtures for facilities.	(1) Expensive comparing to the starter type
Starter type fluorescent lamp	This is the lamp without having a special preheating start mechanism, and the lamp lights up in two seconds or so by means of glow starter generating electrode preheating and kick voltage.	The ballast is small-sized and compact, and the fixture price is the most inexpensive	(1) Immediate lighting can not be done. (2) Replacement of glow starter is needed. (3) Lighting in unison of multi-lamps is unfitted.

As to the lighting fixtures using the type 40 lamp, a possible lighting fixture is different every lamp, and also technological trends, the degree of dissemination and in needs, and so we provides segments focusing attention on the difference of lamps.

Furthermore, characteristics of respective segments and necessity of segmentation are described as follows.

- Since the high frequency lighting dedicated type in segment 2) has been developed in 1991, this type has been available in places lighting wide ranges such as factories and offices, and since the energy efficiency is high, in the future, we need to attempt for more dissemination and promotions. However, since the prices of fixtures and lamps are expensive and the use of dedicated fixtures and lamps is needed and the share of dissemination is 10 percent or so at this time, we shall provide the independent segment.
- Although the type 40 starter type in segment 4) has defects indicated in the above table, this is widely used fixtures in part. This type has been used in places where there becomes no problem in the maintenance man-hour with relatively small scale such as general stores and places where there is no need for a long period use in the temporary buildings such as works sites. Also, this type is the most inexpensive in price, and given that this type is the same segment as segment 3), in order to recover the up-portion of the initial cost covering decreased portions of electricity rate by energy-savings, approximately 11 years used periods are required as a trial calculation at a minimum estimation (Reference 1). Thus, it is high probability that the price increased portions can not be recovered by a decrease of running costs in a certain used periods.

Therefore, the segment 3)4) shall be provided.

● Segments 5)6) (Striplight type 20 starter type)

- The types of fluorescent lamp fixtures used for houses are classified into hanging types and surface mounted types depending on the mounting condition on ceilings, and classified into round shape fixtures and rectangular fixtures depending on the forms. Looking at the classification of used lamps, the round shape fixtures use the circular fluorescent lamps, and the rectangular fixtures use the small striplight type fluorescent lamp (type 20). The selection will be made depending on preferences of consumers.

- Taking a look at the ratio of magnetic ballast and electronic ballast (Inverter) of fixtures having used type 20 striplight fluorescent lamp in segments 5)6), the share of 72.2% is the magnetic ballast. In this type fixture, since the price difference between the magnetic ballast method and the electronic ballast (Inverter) method is large, the magnetic ballast method becomes the major products.

In the economy when replaced the magnetic ballast method fixtures for type 20 - 4 lights with the electronic ballast (Inverter) method, if we try to recover the up-portion of the initial cost covering the decreased portion of electricity rate by energy-savings, approximately 11 years used periods are required as a trial calculation when compared to the electronic ballast (Inverter) method for type 20 - 3 lights with the same brightness (Reference 1). Thus, it is high probability that the price increased portions can not be recovered by a decrease of running costs in a certain used periods.

Therefore, we shall classify from the necessity responding to demand against low price products.

● Segments 7)8)9)10) (Circular type)

- The fixtures having used the circular fluorescent lamps constitute the products in combination with type 40, type 32 and type 30 lamps. Efficiency of these used lamps becomes low in type 30, comparing to others indicating 86.1lm/w in type 40, 83.7lm/w in type 32 and 75.0lm/w in type 30 in the case of three band type neutral white lamps (EX-N).

When providing one segment, since the efficiency of fixtures using type 30 is relatively low, it is difficult to set an appropriate target value.

- In the fixtures for circular type fluorescent lamps, the use configuration in the manner of type 102, type 72 and type 62 has been established according to the space of rooms, it seems appropriate to set the segment adjusting the use needs of consumers.
- Furthermore, the fixtures which the total sum of size classification of used fluorescent lamps are 62 or less, have not been progressing in converting to electronic ballast (Inverter). Also the price difference between the electronic ballast method and the magnetic ballast method is large, since it is high probability that the up-portion of the initial cost can not be recovered by a decrease portion of running costs, we set it as the separate segments. (Reference 1)

● Segments 11)12)(Desk top stand)

- As to the desk top stand, fluorescent lamps used in the desk top stand are mainstream in the compact type and the striplight type. The difference occurs due to lamp attributes just like 66.7lm/w in the compact type and 64.7lm/w in striplight type in the efficiency of these two lamps. In addition, since the use of lamps is set according to the needs of consumers, we shall divide the segmentss.

2. Setting of target values

(1) Excluded special products in setting the target values

As to the high frequency lighting dedicated type of the circular fluorescent lamp fixtures, manufacturers are limited, and since only approximately one year has passed from the introduction into the market, the shipping rate is low in approximately 0.5%. Also, as to the compact type fluorescent lamp fixtures excepting for fluorescent lamp desk top stands, they are used for lighting making use of characteristics of square fixtures. When having set the energy efficiency of the relevant product as the target standard value, the product with widely available technology can not exist. Since it is high probability to extremely distort the market, we excluded it as special products in setting the target value.

However, in setting the target value, we gave consideration for the future proliferation prospects of these fixtures as the efficient improvements by the technological improvements. (Reference 2)

(2) Product distribution and target value

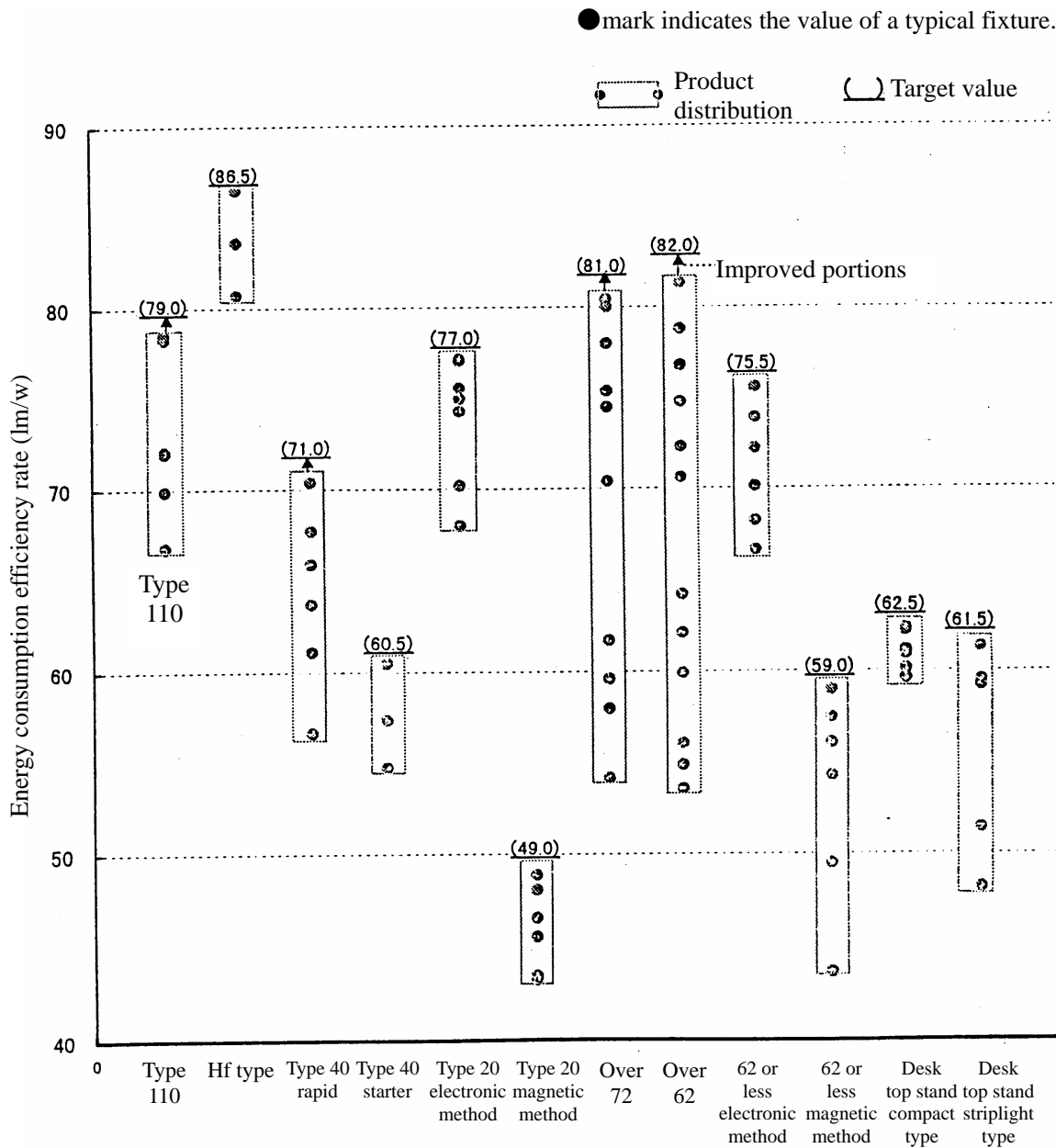

(3) Technological trends

1) Fluorescent lamps

Fluorescent lamps have been firstly commercialized by GE in 1938, the development of new fluorophore, discharge technology and improvements for mass production technology have been performed to date, but the main technical problems include improvements for luminous efficiency, improvements for lumen maintenance factor and reduction of impacts on property by ambient temperature, and the research and development have been carried out.

- Improvements for luminous efficiency have been largely improved by development of three band area luminous type fluorescent lamps, but the quantum efficiency to visible light radiation of this fluorophore has already exceeded 0.8, Large efficiency improvements are difficult to be expected.
- As to improvements for lumen maintenance factor, development of fluorophore which is little deteriorated from ultraviolet rays and chemical reactions during lighting is important. However, its realization is difficult for the short period of time.
- As to reduction of impacts by ambient temperature, if good substitutes replacing with mercury has been developed, the impacts onto total luminous flux by ambient temperature can be expected to be reduced. An effective substance can not be found in the existing substances.

2) Lighting device

The lighting device of fluorescent lamps is roughly classified into the magnetic ballast and the electronic ballast, and the research and development have been carried out according to respective properties.

- Various improvements in the magnetic ballast have been performed for the history of approximately 60 years, and the fundamental part of circuit methods and structures has been already established. A large expectation is made in terms of material progress in the future. However, as to the materials replacing with the existing materials, the development of materials possible to immediately and largely improve can not be expected including the cost problems.
- In the electronic ballast, the luminous efficiency of fluorescent lamps have been improved by approximately 15% comparing to the commercial wave (50/60Hz) lighting through lighting in high frequency using the inverter, thus contributing to energy-savings. However, the high efficiency lighting method replacing with this inverter method as fluorescent lamp lighting device has not been found up to the present.

3) Trends of high frequency lighting dedicated fixtures

High frequency lighting dedicated fixtures, called "Hf fluorescent lamp fixtures" developed in 1991, use fluorescent lamps for high frequency lighting and the dedicated electronic ballast (Inverter), and further high efficient fluorescent lamp fixtures have been realized.

For the high costs of Hf fluorescent lamp fixtures and for the dedicated type fixture, the dissemination rate is still low, but in the future, proliferation of high frequency lighting dedicated fixtures can be expected to be progressed.

3. Setting of the target fiscal year

In the target value of each segment, 10 segments out of 12 segments are the electronic ballast (Inverter) method, and the product of the relevant segmentation should convert to inverter in 100% in the target fiscal year.

As a result, 75% for the whole facilities (segments 1)-4)) and 92.5% for houses (segments 5)-12)) can be expected to go inverted.

As problematic points in inverting,

- 1) The fundamental technology has been already developed, but design and development of circuits compatible with Top Runner's efficiency are required for each enterprise.
- 2) Development of production technology and capital investment in order to attempt for cost reduction are required.
- 3) Development of production technology and capital investment accordance with design and development of fixtures giving consideration for the lamp's temperature properties are

required. But the most important things are the degree of demand (dissemination) and periods required for upgrading the supply system.

Therefore, in setting the target fiscal year, we focused attention on the trends of turning to inverter, and have examined under the conditions that the shortest period able to accomplish the target value on a shipping basis and that considerable efficiency improvements can be expected on a proliferated basis in the year 2010. We set the year 2005 as the target fiscal year.

4. Improvements for energy efficiency

Improvements for energy efficiency judging from the actual results of fiscal year 1996 are estimated as approximately 20% in the fiscal year 2005 based on a certain assumption, when the above-mentioned "Target standard value" was set. (Reference 3)

Running Cost Comparison of Fluorescent Lamp Fixtures (1)

- Comparison between 40 starter type (Magnetic ballast method) and 40 rapid type (Inverter) (For reversed Fuji type 2 lights). (For implantable lower surface open 2 lights)

[Example 1]

Inverter fixture/Yen 22,500 – Glow starter method fixture/Yen 9,300	= Yen 13,200
Inverter fixture	81W X 12h X 250 days X yen 23 /kWh = Yen 5,589
Glow starter fixture	98W X 12h X 250 days X yen 23 /kWh = Yen 6,762
Difference	Yen 1,173
	Yen13,200 ÷ Yen1,173 = 11.25 years ≈ 11.3 years

[Example 2]

Inverter fixture/Yen 23,500 – Glow starter method fixture/Yen 9,300	=Yen 14,200
Inverter fixture	73W X 12h X 250 days X yen 23/kWh=Yen 5,037
Glow starter fixture	93W X 12h X 250 days X yen 23/kWh =Yen 6,417
Difference	Yen 1,380
	Yen14,200 ÷ Yen1,380 = 10.28 years≈10.3 years

[Example 3]

Inverter fixture/Yen 25,600 – Glow starter method fixture/Yen 9,300	= Yen 16,300
Inverter fixture	72W X 12h X 250 days X yen 23/kWh = Yen 4,968
Glow starter fixture	94W X 12h X 250 days x yen 23/kWh = Yen 6,486
Difference	Yen 1,518
	Yen16,300 ÷ Yen1,518 =10.74 years ≈10.7 years

[Compared models]
[Example 1]

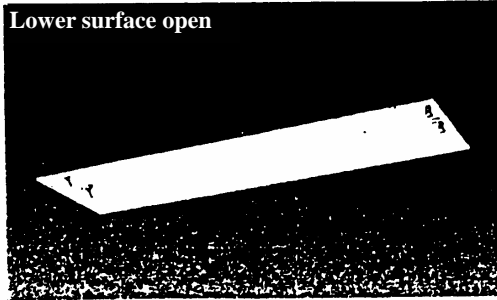

Embedded F424N

(Main body FA42674 + Reflector FK42674)

- ENH ○ Standard price Yen22,500 (Tax excluded)(73/81W)
(82.2/74.1 lm/W)
ENH(200V) ○ Standard price Yen22,500 (Tax excluded) (73/81W)
(82.2/74.1 lm/W)

40W white fluorescent lamp 2 lights
Specification: Steel thickness: Main body 0.6/Reflector 0.6
Main body: Zinc steel plate
Reflector: Steel plate (White)/7.6kg(SUH)/6.8kg(ENH)
Recommended lamp: FLR40S/W/M-X/36
FLR40S/W/ M-X
Total luminous flux: 6000 lm

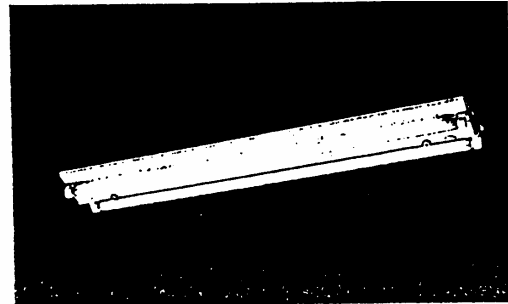

FA42036

GL Standard price Yen9,300 (Tax excluded) (93/98W)(66.7/63.3 lm/W)

40W white fluorescent lamp 2 lights
Specification: Steel thickness: Main body 0.5/Reflector 0.4
Flashing method: 2 lights→Off (GPL)
Main body: Zinc steel plate
Reflector: Steel plate (White)
4.4kg
Recommended lamp: FL40SS/W/37
FL40S/W
Total luminous flux: 6200 lm

[Example 2]



40W 2 lights (Electronic method)

FR-42479K Inverter S
PSI Yen23,500 (73W)(82.2 lm/W)

- Main body: Material thickness: SGC t0.5
- Reflector: White: Material thickness: CGC t0.5
- End plate detachable type in connecting
- Mass: 7.5kg
- FLR40S/W/M/36x2
- Total luminous flux: 6,000 lm

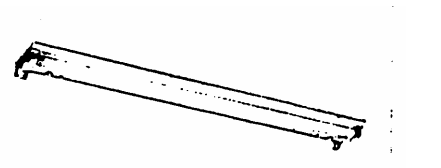

40W 2 lights (Glow method)

FT-88001
GL1 Yen9,300 (93W)(66.7 lm/W)

- Main body: Material thickness: SGC t0.4
- Reflector: White: Material thickness: CGC t0.35
- With connecting guide
- Mass: 4.0kg
- FL40SS/W/37x2
- Total luminous flux: 6,200 lm
- FL40SS/EX-N/37-HX2
- Total luminous flux: 7,120 lm

[Example 3]

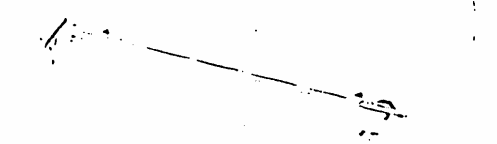

40W2xT
TM4295
With connecting terminal
Plate thickness: Main body 0.6/Reflector 0.6 (White finish)
Mass: 5.6kg

Fixture	TM4294K TM4295		
Lamp	(FLR40S/W/36X2)		
Lighting method	Total luminous flux (lm)	Power consumption (W)	Consumption efficiency (lm/W)
ESC-100/200	6000	(72)	(83.3)

Lighting method	Inventory classification/price
ESC 100	△Yen25,600 Inverter
ESC 200	△Yen25,600 Inverter



40W2xT
NM4203 **Packaging 6** (G2: **Packaging 2**)
With connecting terminal
Main body: Galvanized sheet iron t0.5 **NM4202 substitutes**
Reflector: Steel plate t0.45 White finish
Mass: 3.7kg (GZ, H-100) 3.4kg (H.G-200)
With connecting fitting

Fixture	NM4203		
Lamp	FL40S/W X2 (FL40S/W/37 x 2)		
Lighting method	Total luminous flux (lm)	Power consumption (W)	Consumption efficiency (lm/W)
GZ,H, PGZ-100	6,200	98 (94)	63.3(66.0)

Lighting method	Inventory classification/price
GZ-100	○Yen9,300

[Compared model]
[Example 1]

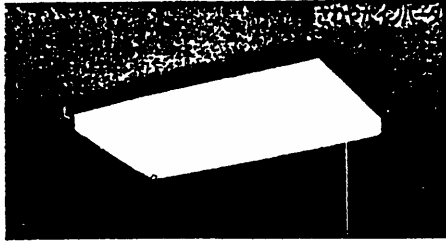

HA6912TEP ○Standard price Yen28,400☆

4.5-6 tatami mats
With step adjusted light features
Simple mounting U-light method
Model with insects and dust being difficult to enter

20W Pallook fluorescent lamp 3 lights
W390/L670/H80/3.3kg
Switch: With pull switch
(Full lighting→Step adjusted light→
Small lamp→Off)
Specification: Acrylic cover (Milk white)
Plastic (Dark brown)
Packaged lamp: FL20SS/EX-N/18
Power consumption: 57W
Total luminous flux: 5,190 lm
Consumption efficacy: 91.1lm/W
Remarks: (Cover mounting, with
cover catch of pushing method)

1 2 3 4 5 6 7 8 9 10 11 12 13 14 15 16 17 18 19 20 21 22 23 24 25 26 27 28 29 30 31 32 33 34 35 36 37 38 39 40 41 42 43 44 45 46 47 48 49 50 51 52 53 54 55 56 57 58 59 60 61 62 63 64 65 66 67 68 69 70 71 72 73 74 75 76 77 78 79 80 81 82 83 84 85 86 87 88 89 90 91 92 93 94 95 96 97 98 99 100

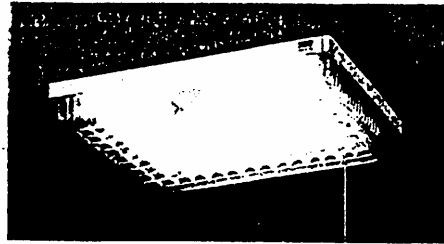

HA8245GPL Standard price Yen12,700☆

6-8 tatami mats
Simple mounting U-light method
Model with insects and dust being difficult to enter

20W full white fluorescent lamp 4 lights
W490/L670/H100/4.8kg
Switch: With pull switch (4 lights→2 lights→Small lamp→Off)
Specification: Acrylic cover (Transparent prism)
Plastic (White)
Packaged lamp: FL20SS/N/18
Power consumption: 86W
Total luminous flux: 4680 lm
Consumption efficacy: 54.4 lm/W
Remarks: (Cover mounting, with cover catch of pushing method)
2.

1 2 3 4 5 6 7 8 9 10 11 12 13 14 15 16 17 18 19 20 21 22 23 24 25 26 27 28 29 30 31 32 33 34 35 36 37 38 39 40 41 42 43 44 45 46 47 48 49 50 51 52 53 54 55 56 57 58 59 60 61 62 63 64 65 66 67 68 69 70 71 72 73 74 75 76 77 78 79 80 81 82 83 84 85 86 87 88 89 90 91 92 93 94 95 96 97 98 99 100

[Example 2]

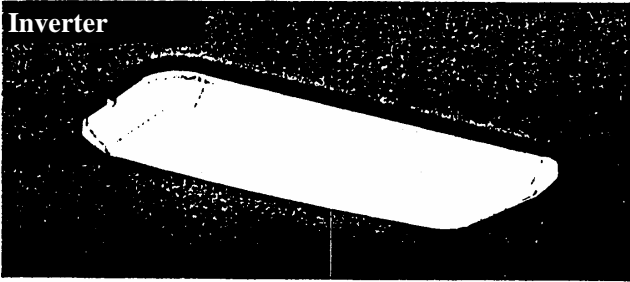

FPH-6800ZK Yen29,000

4.5-6 tatami mats
Fluorescent 60W
Just one
Push method
Clean ace

●Mellow5N fluorescent lamp 20W type/3 lights
(FL20SS/EX-N/18-Hx3)
●Plastic (White)
●Acryl (Milk white)
●Width720 x 300 in height 130 Mass: 2.7kg
●With pull switch (Full light→lighting control 60%→baby bulb→off)
◆With drop prevention function

1 2 3 4 5 6 7 8 9 10 11 12 13 14 15 16 17 18 19 20 21 22 23 24 25 26 27 28 29 30 31 32 33 34 35 36 37 38 39 40 41 42 43 44 45 46 47 48 49 50 51 52 53 54 55 56 57 58 59 60 61 62 63 64 65 66 67 68 69 70 71 72 73 74 75 76 77 78 79 80 81 82 83 84 85 86 87 88 89 90 91 92 93 94 95 96 97 98 99 100

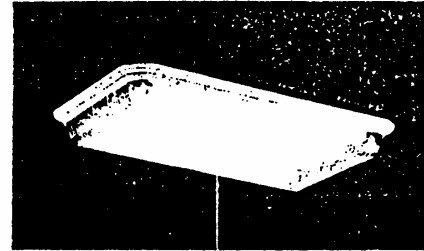

FPH-8520K

6 tatami mats
Fluorescent 80W
Simple mounting screw
Plating rack

Yen12,800

●Mellow white fluorescent lamp type 20W -4 lights
(FL20SS/N/18 x 4)
●Plastic (White)
●Acryl (Transparent)
●Width720 x 410 in height 100 Mass:3.7kg
●With pull switch (Full light→2 lights→baby bulb→off)

1 2 3 4 5 6 7 8 9 10 11 12 13 14 15 16 17 18 19 20 21 22 23 24 25 26 27 28 29 30 31 32 33 34 35 36 37 38 39 40 41 42 43 44 45 46 47 48 49 50 51 52 53 54 55 56 57 58 59 60 61 62 63 64 65 66 67 68 69 70 71 72 73 74 75 76 77 78 79 80 81 82 83 84 85 86 87 88 89 90 91 92 93 94 95 96 97 98 99 100

[Example 3]



FP20113E New Special selection
(Sale scheduled on July 1, 1997)
Yen25,800

Fluorescent 80W
4.5- 6 tatami mats
Switch push-out method
Simple mounting
Model with insects being difficult to enter
Push method A

●20W Lupica fluorescent lamp (Ace color) x 3
●Acrylic cover Milk white
●Metal sheet main body Off-white coating
●Plastic frame Off-white color
●Pull switch switching
(Full lighting→step adjusted light→small lamp→off)
●Width318 length 734 height103 weight2.8kg
Model changed product of FP2533 WE

1 2 3 4 5 6 7 8 9 10 11 12 13 14 15 16 17 18 19 20 21 22 23 24 25 26 27 28 29 30 31 32 33 34 35 36 37 38 39 40 41 42 43 44 45 46 47 48 49 50 51 52 53 54 55 56 57 58 59 60 61 62 63 64 65 66 67 68 69 70 71 72 73 74 75 76 77 78 79 80 81 82 83 84 85 86 87 88 89 90 91 92 93 94 95 96 97 98 99 100

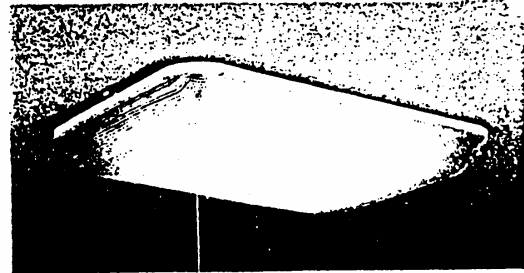

FP20304 New Special selection
Yen14,800

Fluorescent 80W
4.5- 6 tatami mats
Simple mounting
Switch push-out method
Model with insects being difficult to enter
Push method A

●20W type lumi-crystal fluorescent lamp x 4
●Plastic cover with transparent pattern
●Steel plate main body Off-white color coating
●Plastic frame Off-white color
●Pull switch switching
(4 lights→2 lights→small lamp→off)
●Width518 length734 height 103 weight5.0kg
Model changed product of FP2144

1 2 3 4 5 6 7 8 9 10 11 12 13 14 15 16 17 18 19 20 21 22 23 24 25 26 27 28 29 30 31 32 33 34 35 36 37 38 39 40 41 42 43 44 45 46 47 48 49 50 51 52 53 54 55 56 57 58 59 60 61 62 63 64 65 66 67 68 69 70 71 72 73 74 75 76 77 78 79 80 81 82 83 84 85 86 87 88 89 90 91 92 93 94 95 96 97 98 99 100

[Example 4]

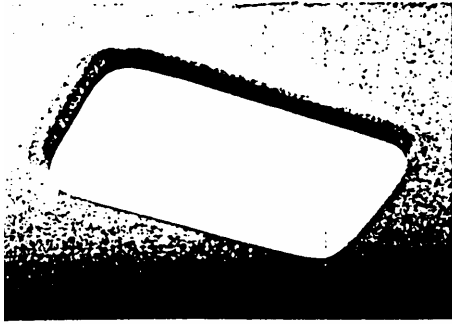

FC6B14E Standard price Yen38,000

- Fluorescent lamp 60W type, for 4.5-6 tatami mats (Type 20, 3 lights)
- Cover: Milky white acryl
 - Frame: Melamine coating (Black)
 - Cover removable: Clutch method
 - With pull switch (Full lighting, step adjusted light, safety bulb, light-out)
 - Length730, width414, height120mm
 - 5.2kg
- [Simple mounting type]
[Insect proof structure]
[Acryl]
Comfortable IC inverter with brightness
- 

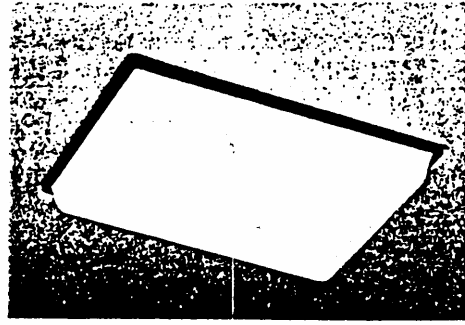

FC8648 Standard price Yen14,800

- Fluorescent lamp 80W type for 4.5-6 tatami mats (Type 20, 4 lights) With high white [Simple mounting type] [Acryl]
- Cover: Milky white acryl
 - Frame: Melamine coating (Brown)
 - With pull switch (80W-40W, safety bulb, light-out)
 - Cover removable: Push-fit
 - Length680, width592, height 99mm
 - 4.2kg
- 

[Example 5]

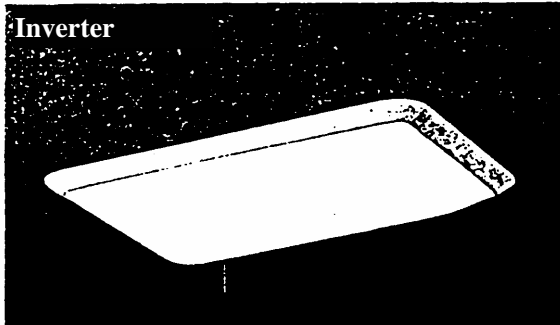

AHN 330 044 Yen25,800 4.5-6 tatami mats

- Fluorescent 60W
- Striplight fluorescent lamp FL 20WX3 (With small lamp)
 - Plastic: White
 - Acryl: Milky white
 - Full lighting→step adjusted light→small lamp→off
 - Height105, width744 X 456mm Weight3.1kg
 - Simple mounting type (Only embedded ceiling block)
 - High color rendering lamp
 - Consumption efficacy: 85.4 lm/W 5.292 lm/62W
 - Lamp: FL20SS/EX/N18 x 3
- With switch
Plating rack
- 

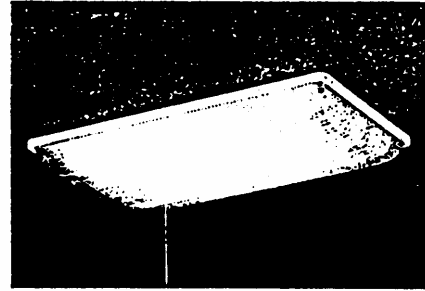

AHG 330 052 6 tatami mats
Yen12, 800

- Fluorescent 80W
- Striplight fluorescent lamp FL 20W X 4 (With small lamp)
 - Steel/ white coating
 - Plastic: Transparent
 - 80W→40W→small lamp→off
 - Height102, width 703 X 418mm Weight:4.4kg
 - Simple mounting type (Only embedded ceiling block)
 - Consumption efficiency 53.2 lm/W 4.68C lm/88W
- With switch
Plating rack
- 

[Example 6]



OL 131 901

- Fluorescent 60W 4.5-6 tatami mats
- High color rendering striplight fluorescent lamp (20W x 3)
 - With switch Full lighting 100%→Full light 60%→small lamp→off
 - Steel plate (Off-white coating)
 - Antistatic acryl
 - Width 385 length694 height85 3.5kg
 - Power consumption 69 W
- Simple mounting type
Plating rack
SAVE
- 

Yen26,800

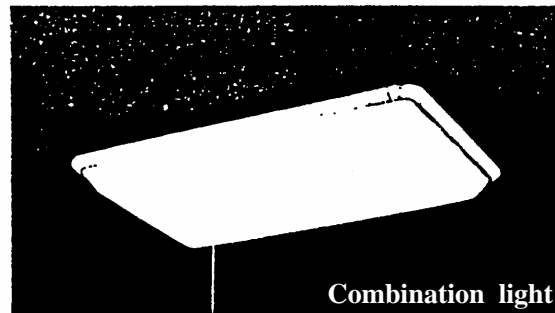

OL 131 198

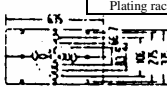
- Fluorescent 60W 4.5-6 tatami mats
- Striplight fluorescent lamp(20W X 4)
 - With switch 80W→40W→small lamp→off
 - Steel plate (Off-white coating)
 - Antistatic acryl
 - Width445 length694 height85 4.7kg
 - Built-in type plating rack ceiling (capacity 300 W, always energization circuits) (Power consumption 92W)
- Simple mounting type
Combination light
Plating rack
- 

Yen15,800

Running Cost Comparison of Fluorescent Lamp Fixtures (3)

- Comparison of circular lamp type 62 between with the magnetic ballast method and with the inverter fixture.

[Example 1]

Inverter fixture	Yen 12,900	-	Magnetic ballast method fixture	Yen 8,000	=	Yen 4,900
Inverter fixture			72W X 6h X 340 days X yen 23/kWh			= Yen 3,378
Magnetic ballast method fixture			80W X 6h X 340 days X yen 23/kWh			= Yen 3,754
Difference						Yen376
Yen4,900 ÷ Yen376 = 13.03 years ≈ 13.0 years						

[Example 2]

Inverter fixture	Yen 20,900	-	Magnetic ballast method fixture	Yen 12,400	=	Yen 8,500
Inverter fixture			64W X 6h X 340 days x yen 23/kWh			= Yen 3,003
Magnetic ballast method fixture			67.5W X 6h X 340 days X yen 23/kWh			= Yen 3,167
Difference						Yen164
Yen8,500 ÷ Yen164 = 51.83 years ≈ 51.8 years						

[Example 3]

Inverter fixture	Yen 20,800	-	Magnetic ballast method fixture	Yen 12,800	=	Yen 8,000
Inverter fixture			64W X 6h X 340 days X yen 23/kWh			= Yen 3,003
Magnetic ballast method fixture			73W X 6h X 340 days X yen 23/kWh			= Yen 3,425
Difference						Yen422
Yen8,000 ÷ Yen422 = 18.95 years ≈ 19.0 years						

[Example 4]

Inverter fixture	Yen 21,500	-	Magnetic ballast method fixture	Yen 17,500	=	Yen 4,000
Inverter fixture			62W X 6h X 340 days X yen 23/kWh			= Yen 2,909
Magnetic ballast method fixture			69W X 6h X 340 days X yen 23/kWh			= Yen 3,237
Difference						Yen328
Yen4,000 ÷ Yen328 = 12.19 years ≈ 12.2 years						

(Note) These are comparisons between the used lamps is the same and the lighting method is different, the quantity of light (total luminous flux) and recommended tatami mat number (space of room) are different.

[Compared model]

[Example 1]

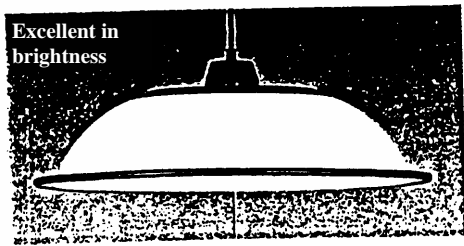

RP775E Open price*

Fluorescent lamp 62W type for 6-8 tatami mats (70W type)
Circular type 32 (High illuminance type 40) + type 30
With EX-D color
Step adjusted light
Comfortable IC inverter with brightness

- Shade: Milky white styrol
- Ornament band (Black)
- With 40 cm hoisting attachment
- With pull switch
- (Full lighting/step adjusted light/safety bulb/light-out)
- Width 502 φ, height 105mm
- 2.1 kg

Packaged lamp: FCL32EX-D/30
FCL30EX-D/28
Power consumption: 72W
Total luminous flux: 5420lm
Consumption efficiency: 75.3 lm/W

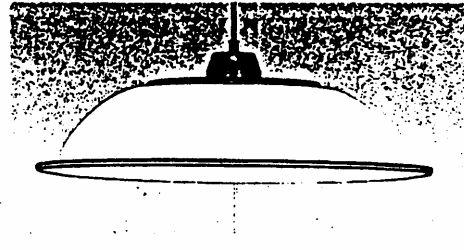

RP7701 Standard price Yen8,000

Fluorescent lamp 70W type for 4.5-6 tatami mats
Circular type high illuminance type 40 + type 30
(Used lamp 32 type)
With EX-D color

- Shade: Milky white styrol, ornament band (Black)
- With 40cm hoisting attachment
- With pull switch
- (70W/30W/Safety bulb/light-out)
- Width 502 φ, height 105mm
- 2.8 kg

Packaged lamp: FCL32EX-D/30
FCL30EX-D/28
Power consumption: 80W
Total luminous flux: 4640lm
Consumption efficiency: 58.0lm/W

[Example 2]

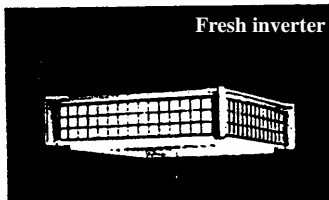

HD8920T EPH

Standard price Yen20,900☆
(32W + 30W) Round shape Palook fluorescent lamp
W 423/H138/2.6kg
Switch: With pull switch (Full lighting → step adjusted light → small lamp → off)
Specification: Plastic shade (Milky white)
Plain wood finish
With cord 55cm
With rectangular flange
With plating rack ceiling

Packaged lamp: FCL32EX-N/30
FCL30EX-N/28

Power consumption: 64W
Total luminous flux: 5700lm
Consumption efficiency: 89.1 lm/W

6-8 tatami mats
With step adjusted light function

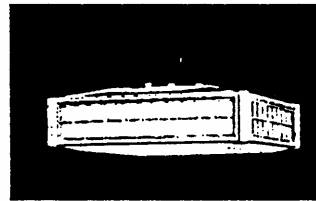

HD9118T GPL

Standard price Yen12,400☆
(32W + 30W) Round shape Palook fluorescent lamp
W 452/H152/3.4kg
Switch: With pull switch (62W → 32W → small lamp → off)
Specification: Plastic shade (Milky white)
With cord 40cm
With rectangle flange
With plating rack ceiling

Packaged lamp: FCL32EX-N/30
FCL30EX-N/28

Power consumption: 67.5W
Total luminous flux: 4610 lm
Consumption efficiency: 68.3 lm/W

4.5-6 tatami mats

[Example 3]

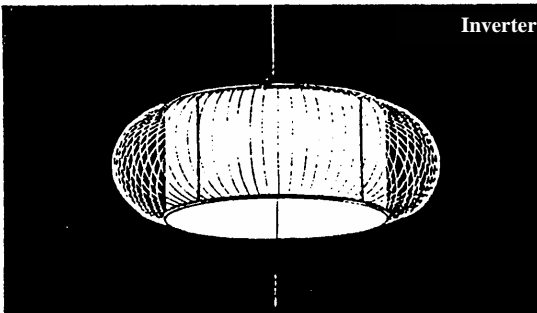

OP 171 548

Fluorescent 62W
6-8 tatami mats
SAVE

- High color rendering round shape fluorescent lamp (32W + 30W)
- With switch Full lighting 100% → full lighting approximately 60% → small lamp → off
- Plastic protection
- Japanese paper mixed plastic sheet
- Cord 45cm, adjustable cord length
- Diameter 510 φ height 177 1.8kg

Yen20,800

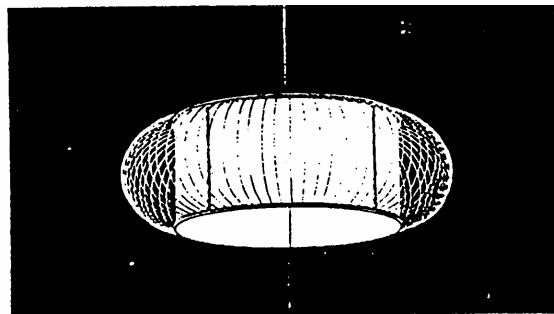

OP 171 551

Fluorescent 62W
4.5-6 tatami mats

- Round shape fluorescent lamp (32W + 30W)
- With switch 62W → 32W → small lamp → off
- Plastic protection
- Japanese paper mixed plastic sheet
- Cord 45cm, adjustable cord length
- Diameter 510 φ height 177 2.5kg

Yen12,800

[Example 4]

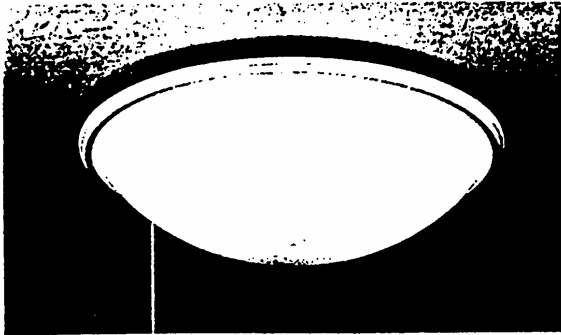

DCL-31859

Yen21,500 (With lamp)



Fluorescent 62W
6 tatami mats

- 32W + 30W High color rendering neutral white round shape fluorescent lamp
- Plastic: stone blue color
- Plastic: oval color (Grain processing)
- Diameter ϕ 565 height 165 mm 3.6kg
- With movable lateral switch (100% - 60% - 5-0)
- Pull less switch mounting possible (Separately ordered)



Simple mounting method
Cover rotation method
Movable lateral switch
Low temperature design for ceiling surface
Type with insect being difficult to enter

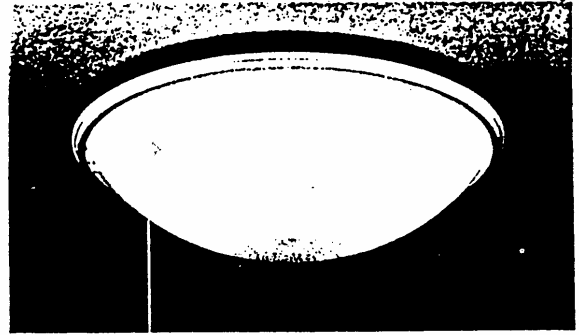

DCL-31857

Yen17,800 (With lamp)



Fluorescent 62W
4.5 tatami mats

- 32W + 30W Neutral white round shape fluorescent lamp
- Plastic: stone blue color
- Plastic: oval color (Grain processing)
- Diameter ϕ 565 height 165 mm 4.4kg
- With movable lateral switch (62- 32- 5- 0)



Simple mounting method
Cover rotation method
Movable lateral switch
Type with insect being difficult to enter

[Improved portion of efficiency by technical development]

1. Introduction of conceivable new technology
 - (1) Introduction of lamp for high frequency lighting

Category classification	Subject lamp			Remarks
110W rapid	Compact type	FHP105		92 lm/W
40W rapid	Compact type	FHT42	FHP45	75 lm/W
Circular type	Circular type	FHD40	FHD70 FHD100 FHC20 FHC27 FHC34	88 lm/W

* The numerical value is the estimated value according to the revised measuring method.

- (2) Lighting device

In order to attempt for the switchover to the electronic ballast (Inverter), it is expected that improvements for inverter circuits and electronic parts to reduce the costs and improvements for the production technology have progressed. We stand a chance of improving the energy efficiency through facilitation of this conversion to inverter in order to accomplish the target value.

- (3) Expansion of lighting control system

For the purposes of not only energy-savings but also convenience and comfort of lighting environment, various lighting control systems have been developed and expanded. As the control methods, there are 1) Time schedule control, 2) Daylight sensor control, 3) Human sensitive sensor control, 4) Remote control, etc.

These controls are not to heighten the energy efficiency (lm/W) of individual single fixture, but to attempt for energy-savings of the whole lighting facilities functioning effectively as the system.

2. Trial calculation for improved portions of energy efficiency

	Estimated structural ratio of shipment in 2005	Energy efficiency in 2005		Improved portion of efficiency
1) Type 110 rapid	Top runner inverter fixture	95%	78.3 x 0.95	0.7 lm/W
	FHP105 fixture	5%	92.0 x 0.05	
3) Type 40 rapid	Top runner inverter fixture	90%	70.4 x 0.90	0.3 lm/W
	FPL36, 55 fixture	5%	71.8 x 0.05	
	FHT42, FHP45 fixture	5%	75.0 x 0.05	
7) Over circular type 72	Top runner inverter fixture	90%	80.4 x 0.90	0.8 lm/W
	FHD, FHC fixture	10%	88.0 x 0.10	
8) Over circular 62	Top runner inverter fixture	90%	81.3 x 0.90	0.7 lm/W
	FHD, FHC fixture	10%	88.0 x 0.10	

(Note) Improved portions of efficiency mean the improved portion against Top Rrunner value.

Trial Calculation Related to Improvements of Energy Efficiency

1. Target value of energy efficiency

Result values in fiscal year 1997 (Weighted average energy efficiency)

	Current measuring method		Estimated value in revised measuring method
For facilities	75.1 lm/W	→	65.1 lm/W
For households	70.1 lm/W	→	60.1 lm/W

(Note) In the measurement by the revised measuring method, the current result value is estimated to be reduced by 10-15 lm/W.

2. Improved ratio trial calculation for energy efficiency

1) Weighted average energy efficiency of the actual results in fiscal year 1997: 63.10 lm/W

* As to the shipping structure, the data in fiscal year 1997 is used.

2) Weighted average energy efficiency in fiscal year 2005: 73.56 lm/W

* As a prerequisite, the shipping structure ratio is the same as 1).

$$\underline{(73.56 - 63.10) \text{ lm/W} \div 63.10 \text{ lm/W} = 16.58\%}$$

Measuring Methods

1. Terms

- (1) Total luminous flux: The total sum of luminous flux which light source is emitting to all directions.
- (2) lm (Lumen): This is a unit of luminous flux in the International System of Unit. This indicates the magnitude of luminous flux discharged into the pyramid of solid angle 1 sr (Steradian) from the point light source having luminous intensity of 1 cd (Candera) equal to all directions.

2. Calculation of total luminous flux of fluorescent lamps installed to fluorescent lamp fixtures
The calculation of total luminous flux (hereinafter referred to as “Total luminous flux”) of fluorescent lamps installed to fluorescent lamp fixtures is performed as follows.

Total luminous flux shall be the value multiplying the total luminous flux value (hereinafter referred to as “lamp rated total luminous flux value”) of the single fluorescent lamp measured and published by JIS C 7601 by the “ballast light output coefficient” and the “temperature correction coefficient” actually measured by the method mentioned below.

Total luminous flux = (Lamp rated total luminous flux value) X (Ballast light output coefficient)
X (Temperature correction coefficient)

- (1) Measurement of ballast light output coefficient

The ballast light output coefficient uses the ratio of the light output value of the practical ballast measured by the following method and of the light output value of the ballast for tests.

$$\text{Ballast light output coefficient} = \frac{\text{Light output of the practical ballast}}{\text{Light output of the ballast for tests}}$$

- 1) Measuring conditions

Ambient temperature of the ballast shall be 25 ± 2 °C.

- 2) Measuring methods

Light output of the magnetic ballast shall be measured by the rule of “6.2.6 Lamp current and lamp power test” in JIS C 8108 “Fluorescent lamp ballast”. Light output of electronic ballast shall be measured by the rules of “6.2.6 Lamp current and light output test” in JIS C 8117 “Fluorescent lamp electronic ballast”.

- (2) Measurement of temperature correction coefficient

Temperature correction coefficient shall be determined by the “Tube wall temperature – Standard of luminous flux curves” (established by Japan Electric Lamp Manufacturers Association) of the relevant lamp corresponding to the tube wall temperature obtained by the following method.

- 1) Measuring conditions

The measuring conditions shall be performed as follows unless otherwise specified.

- (a) Ambient temperature of the fluorescent lamp fixtures shall be 25 ± 2 °C.
- (b) Mounting conditions of fluorescent lamp fixtures shall be performed on the condition of mounted on the simulated ceiling to which conditions were specified in the ordinary temperature rise test of JIS C 8106 “Fluorescent lamp fixtures for facilities” or JIS C 8115 “Fluorescent lamp fixtures for households”.

- (c) Lamps used for measurement are the ones specified in “Appendix 2 lamps for tests” of JIS C 8108 “Fluorescent lamp ballast”.
- (d) Measurement is performed after the tube wall temperature of the lamp stabilizes.
- (e) Input of the ballast shall be the rated voltage of the rated frequency.

2) Measurement of tube wall temperature

Equip the lamp for tests of 1)(c) with the relevant fluorescent lamp fixtures, and hold the mounting conditions of (b) and the ambient temperature of (a). After inputting the rated frequency and the rated voltage of the ballast of (e), light it up, and measure the coldest point temperature of the lamp tube walls after continuing until it becomes the conditions of (d).

3. Measurement of power consumption

Measurement of power consumption shall be performed by the method specified in the input test of JIS C 8105, and after measuring the tube wall temperature of 2. (2) 2), measurement shall be made in the same condition.

(Reference)

At this time, the measurement methods of energy efficiency were revised (Measurement of ballast light output, measurement of lamp’s tube wall temperature) in order to more accurately reflect on the actual use of the lighting fixtures. It is estimated that the energy efficiency (lm/W) measured by this method is smaller by approximately 10 – 15 % (Approximately 10 lm/W) than the value measured by the current measuring method.

Tube wall temperature of fluorescent lamps- Standards of luminous flux curves (Example of FCL32/30)

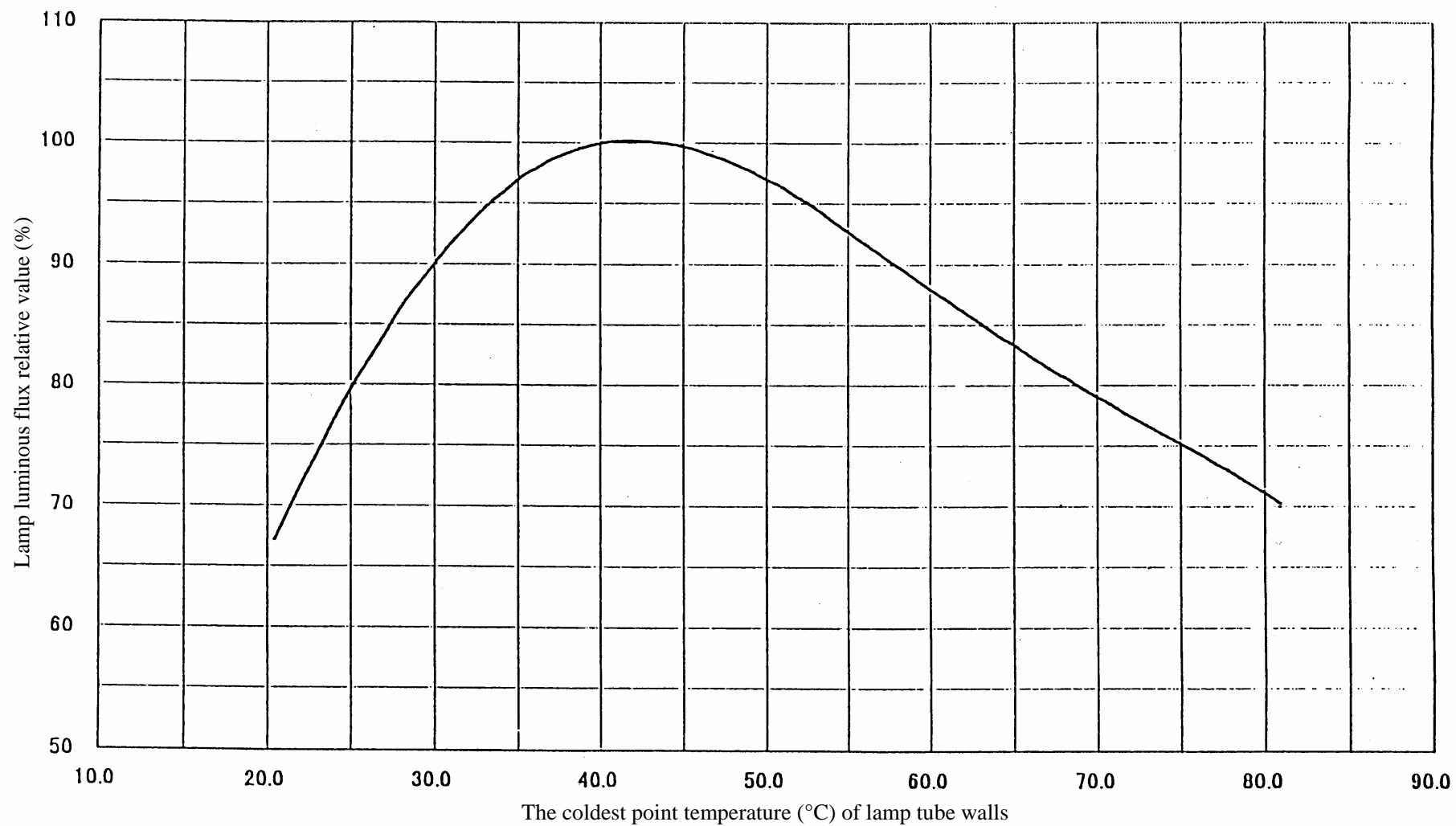

History of the Fluorescent Lighting Fixtures Criteria Subcommittee

First committee meeting (July 27, 1998)

- Status quo of fluorescent lamp fixtures
- Target range
- Measurement methods of energy efficiency
- Segmentation for target setting

Second committee meeting (Aug. 20, 1998)

- Measurement methods of energy efficiency
- Segmentation for target setting
- Target standard values
- Display items

Third committee meeting (Sep. 9, 1998)

- Interim report

Fourth committee meeting (Dec. 1, 1998)

- Opinions about the interim report
- Final report

(Exhibit 5)

Fluorescent Lighting Fixtures Criteria Standard Subcommittee,
Energy Efficiency Standards Subcommittee of the Advisory Committee on Energy:
List of Members

Chairman	Hiromitsu Ishii	Professor of Department of Electrical Engineering, College of Science and Technology, Nihon University
	Michiko Saeki	Japan Consumer's Association
	Kazuko Sato	Director of Nippon Association of Consumer Specialists
	Shinji Sawata	Technical specialist of Energy Conservation Center, Japan
	Yasuo Nakagawa	Professor of Department of Electrical and Electronic Systems, Faculty of Engineering, Saitama University
	Yutaka Nagata	Assistant professor of Graduate School of Energy Science, Kyoto University
	Yasuhiko Nakane	Managing director of Japan Machinery Importers' Association
	Yukio Nakano	Senior researcher of Komae laboratory, Central Research Institute of Electric Power Industry
	Kazuo Nakamura	Professor of Department of Management and Information System Science, Faculty of Engineering, Nagaoka University of Technology
	Hiroo Hasegawa	Chief researcher of Department of Energy Engineering, Mechanical Engineering Laboratory, Agency of Industrial Science and Technology,
	Taisuke Hirota	Managing director of Japan Electric Lamp Manufacturers Association
	Yusaku Matsushima	Managing director of Japan Luminaries Association

Present circumstances of types of fluorescent lamp fixtures and energy consumption volume

1. Types of fluorescent lamp fixtures

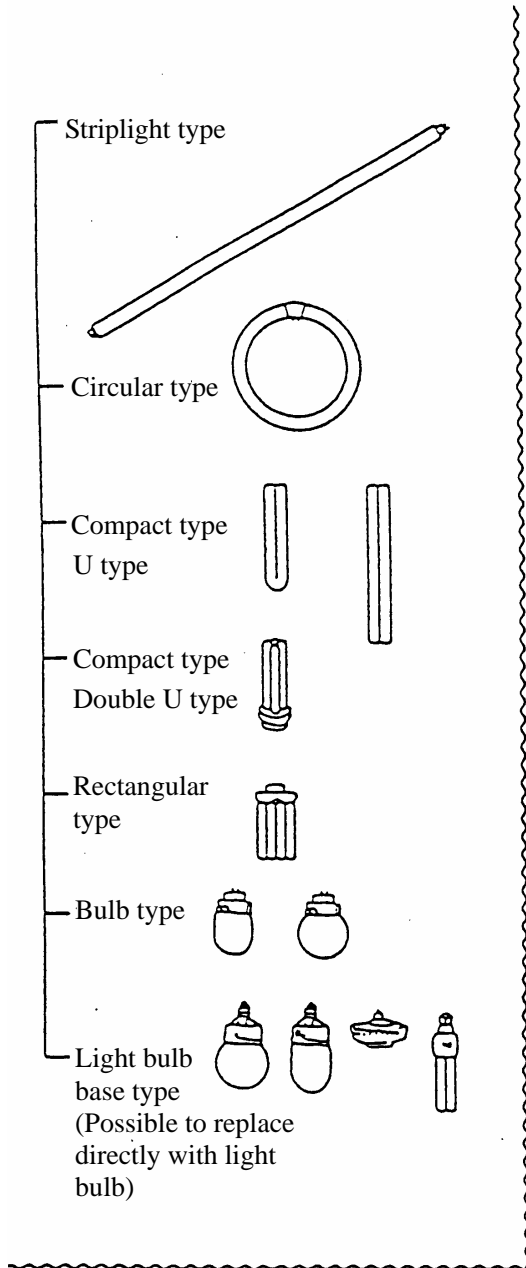

1) Striplight fixtures with less than 40W

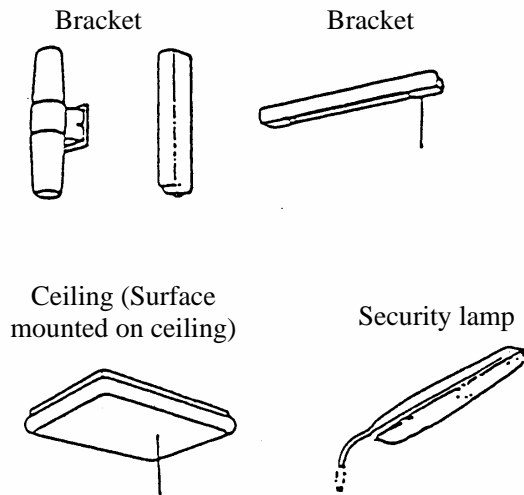

2) Striplight fixtures with more than 40W

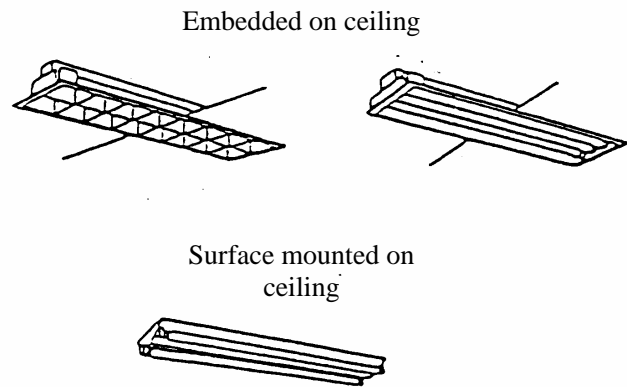

3) Circular type tube fixture

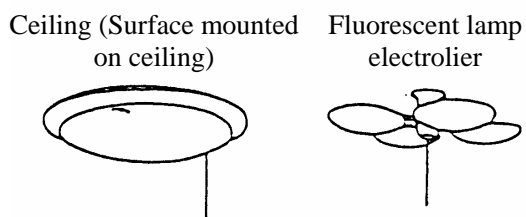

4) Stand

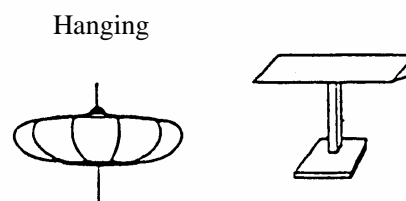

1.2 Dissemination circumstances

(1) Transition of shipping quantity

(Unit) Quantity: in the thousands Over the previous year: %

Classification/year	1993		1994		1995		1996		1997	
Fluorescent lamp fixtures	46,290	192.7	46,737	101.0	47,468	101.6	49,885	105.1	50,959	102.2
Striplight 40 watt or more	18,213	87.7	17,734	97.4	17,991	101.4	18,376	102.1	19,016	103.5
Striplight less than 40 watt	16,227	95.1	16,293	100.4	15,016	92.2	14,648	973.5	14,860	101.4
Circular type tube fixture	10,506	99.2	11,049	105.2	12,689	114.8	14,973	118.0	15,187	101.4
Stand	1,344	87.7	1,661	123.6	1,772	106.7	1,888	106.5	1,896	100.4
Incandescent lamp fixture	18,434	97.4	18,914	102.6	19,138	101.2	22,071	115.3	23,025	104.3
For general	16,390	99.4	16,935	103.3	17,161	111.3	20,003	116.6	20,879	104.4
For special	2,044	84.1	1,979	96.8	2,068	104.6	2,068	104.6	2,146	103.8
High pressure discharge lamp fixtures	3,516	93.9	3,491	99.3	3,551	101.7	3,525	99.3	3,391	96.2
Total	68,240	94.0	69,142	101.3	70,157	101.5	75,481	107.6	77,375	102.5

Source: Production dynamic statistics of the Ministry of International Trade and Industry (Incandescent lamp fixtures for motor vehicles are excluded.)

Transition graph of shipping quantity

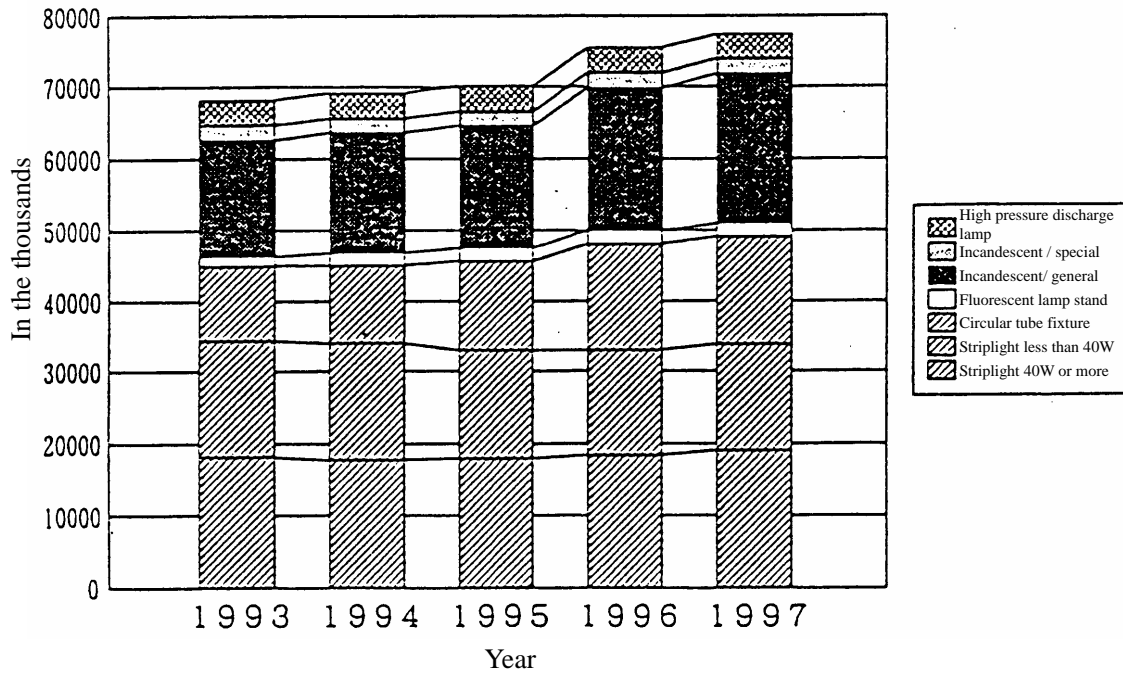

(3) Power consumption volume every group (Shipping basis in 1997)

Group name	Shipping quantity (in the thousands) (Percentage%)	Power consumption volume (Million kWh/year) (Percentage%)
110 rapid	894 (2.0)	459 (6.4)
40 rapid	9,340 (20.9)	2,410 (33.8)
Hf 32/45	1,182 (2.6)	340 (4.8)
40 starter	4,550 (10.2)	655 (9.2)
Circular tube fixture	13,733 (30.7)	2,269 (31.8)
20 starter	3,257 (7.3)	591 (8.3)
Stand	966 (2.2)	23 (0.3)
Less than 40 (1 light)	10,843 (24.2)	390 (5.5)
Total	44,766 (100.0)	7,138 (100.0)

(4) Approach to energy-savings in foreign countries

1) EC countries

○ Efficiency of “Fluorescent lamp + Fluorescent lamp ballast”

Input electric power of the ballast is classified into 7 categories, indicating as EEI (Energy efficiency index).

Subject: For 7 types of striplight lamp and compact type lamp 22

Standard: C.E.L.M.A. (Rules for the Federation of National Manufactures Associations for Luminarieres and Electrotechnical for Luminarieres in the European Union. In the future, it is scheduled to standardize EN.)

○ Standardization of the evaluation (C.E.L.M.A) including optical performance of lighting fixtures will be started from now on.

2) U.S.

○ Rules related to efficiency of fluorescent lamps and color rendering properties

The minimum value is specified in 4 types of lamps. Obligatory indication. (Energy Policy Act. Pf1992)

○ Efficiency rules for fluorescent lamp ballast

The minimum efficiency index (Magnetic method and electronic method are classified) is set as to 10 types of ballast, and the mark is indicated on the ballast which cleared efficiency. (Public Law 100-357)

○ Evaluation of efficiency of fluorescent lamp fixtures

The minimum value (By groups, by light number) of efficiency evaluation is provided against 5 types of facility fixture groups (With embedded covers, with embedded louver). (NEMA (National Electrical Manufacturers' Association) standards)

Changes of lamp development and transition of fluorescent lamp power consumption

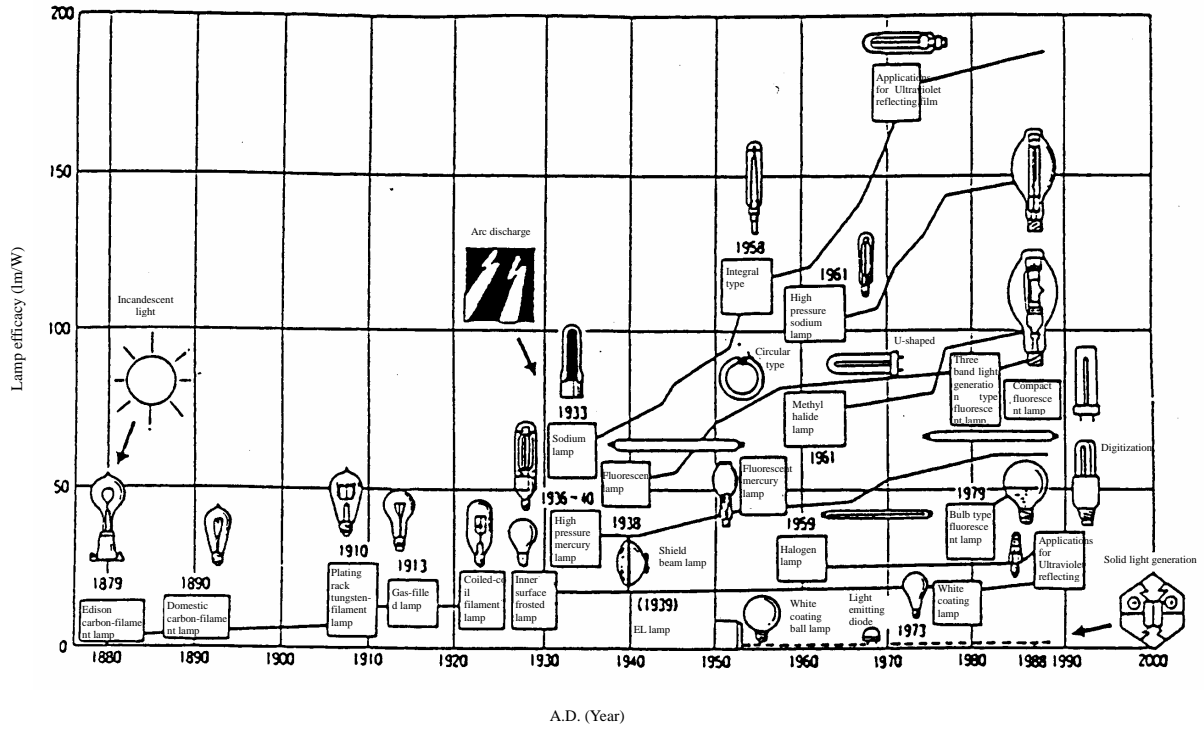
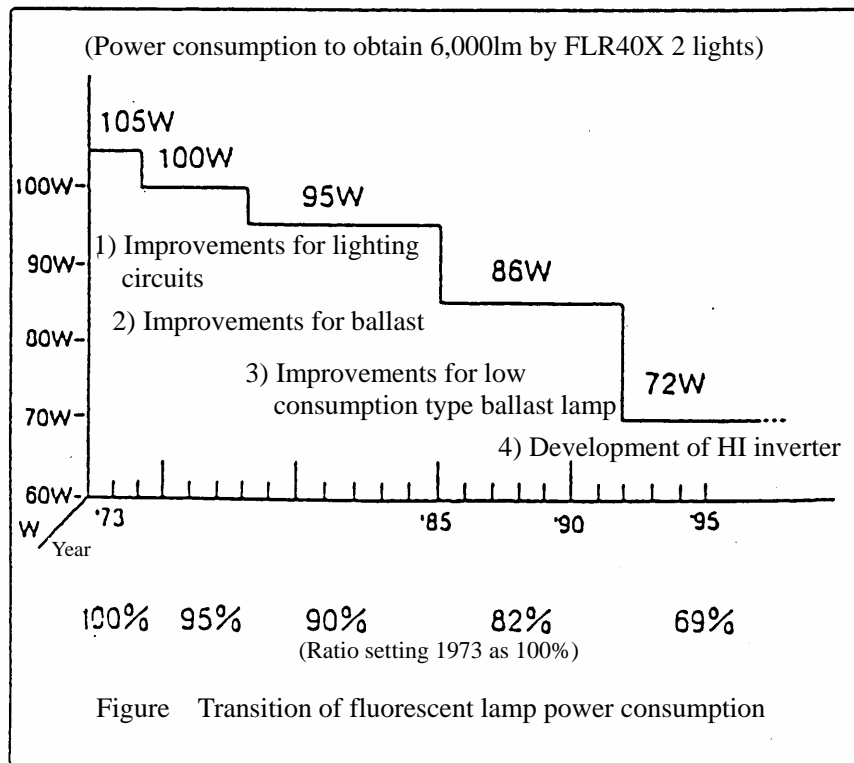

Figure Improvement for lamp efficacy



Law related to rationalization of energy use
Related current ministerial ordinance (Excerpt)

(Specific instruments)

Cabinet order article 7

Mechanical fixtures specified in the cabinet order of Article 18, item 1 are as follows.

1. Passenger cars (gasoline shall be a fuel with riding capacity being 10 persons or less, and cars having received the designation of Road Trucking Vehicle Law (Statute No.185 in 1951) Article 75 Item 1 about its model are only certified, and 2 wheeled vehicles (side cars are included) and the endless track types are excluded.)
2. Air conditioners (air conditioners for use of heating are included, and air conditioners having cooling capacity with more than 27 KW and water cooling type and other air conditioners specified in the ordinance of the Ministry of International Trade and Industry are excluded.)
3. Lighting fixtures which only fluorescent lamps become the main light source (Explosion-proof type and the other types specified in the ordinance of the Ministry of International Trade and Industry are excluded.)
4. TV receiver (Receivers having cathode-ray tube and being used in cable run of alternating current are only certified, and the industrial use ones are excluded.)
5. Copying machine (Copying machines of the dry type indirect electrostatic type are only certified, and color copying machine and other copying machines specified in the ordinance of the Ministry of International Trade and Industry are excluded.)
6. Electronic computers (Electronic computers specified in the ordinance of the Ministry of International Trade and Industry are excluded as the one having highly processing capacity.)
7. Magnetic disk device (Magnetic disk device with 200 mega bytes or less in memory capacity is excluded.)
8. Motor trucks (Gasoline shall be a fuel, and motor trucks having gross vehicle weight of 2.5 tons or less specified in Road Trucking Vehicle Law Article 40 Item No.3 and having received the designation of the same law Article 75 Item No.1 about its model are only certified, and 2 wheeled vehicles (Side cars are included) and the endless track types are excluded.)
9. VCRs (VCRs used in cable run of alternating current are only certified, and industrial ones and other VCRs specified in the ordinance of the Ministry of International Trade and Industry ministerial ordinances are excluded.)

(Contracting-out of specific instruments)

Ministerial ordinance Article 12

Air conditioners specified in the ordinance of the Ministry of International Trade and Industry of Decree article 7 No.2 are as follows.

1. Air conditioners with structures not having motors for compression
 2. Air conditioners with structures using energy other than electricity as heat source of heating
 3. Air conditioners with structures having the temperature control function for the purposes of performance maintenance of machinery and apparatus or of air harmonization for sanitary supervision of food and drink, or having cleaning performance
 4. Air conditioners with structures cooling air of outdoor and sending air inside the room
 5. Spot air conditioner
 6. Air conditioners designed for vehicles and other transportation
 7. Air conditioners with structures having ducts in air supply and exhaust opening of heat exchanger on the outdoor side
 8. Air conditioners with structures used connecting more than 2 indoor machines in one outdoor machine which is the separated type
2. Lighting fixtures using only fluorescent lamps specified in the ordinance of the Ministry of International Trade and Industry of Decree article 7 No.3 as main light source are as follows.
1. Heat-resistant types
 2. Dustproof structure types
 3. Corrosion-resistant types
 4. Types designed for vehicles and other transportation
 5. Lighting fixtures using less than type 40 fluorescent lamps (Hanging type for households and fluorescent lamp fixtures for desk top stand are excluded.)
3. Copying machines specified in the ordinance of the Ministry of International Trade and Industry of Decree article 7 No.5 are as follows.
1. Copying machines with structures which copying is possible on more than A2 size paper
 2. Copying machines with structures which copying is possible at the speed of more than 86 sheets per one minute
 3. Copying machines with integral structures with the printing system
 4. Copying machines with integral structures with the facsimile system
4. In electronic computers specified in the Ministry of International Trade and Industry ministerial ordinances of Decree article 7 No.6, the complex theory performance (The electronic computers enumerated in the upper column of the attached sheet 2 shall be the one listed in the lower column of the same table.) shall be more than 3,000 mega operation per one second.
5. VCRs specified in the ordinance of the Ministry of International Trade and Industry of Decree article 7 No.9 are as follows.
1. VCRs with structures processing the electrical signal involving in voices and images by the digital method
 2. VCRs with structures processing the electrical signal which the number of scanning lines involves in more than 1,125 pieces of images
 3. VCRs processing the electrical signal which the horizontal resolution involves in more than 400 pieces of images and with structures not having the satellite broadcasting receiving functions
 4. VCRs with structures having multiple actuators of video tapes
 5. VCRs with structures having only playback functions

Criteria of manufacturers related to performance improvements of lighting fixtures using only fluorescent lamps as main light source

(May 30, 1994 Notification No.367 of the Ministry of International Trade and Industry
Revision Jan.9, 1995 Notification No.7 of the Ministry of International Trade and Industry)

1. Criteria

Manufacturers or importers (Hereinafter referred as to “Manufacturers”) of lighting fixtures (Hereinafter referred as to “Fluorescent lamp”) using only fluorescent lamps enumerated in the law enforcement decree (Cabinet order No.267 in 1979) Article 7 No.3 related to rationalization of energy use as the main light source, shall not fall below of the numerical value enumerated in the right column of the same table in the value which is derived from a weighted average of the energy consumption efficiency of fluorescent lamps shipping to the domestic market by shipping units every classification enumerated in the left column of the next table in 2000 (It means the year commencing April 1, 2000 through March 31, 2001.).

Furthermore, the energy consumption efficiency shall be the numerical value obtained dividing the numerical value indicating total luminous flux measured according to the measurement method of 3 in lumen by the numerical value indicating power consumption measured by the method specified in the input test of the Japanese Industrial Standard C8105 in watt.

Classification	Standard energy consumption efficiency
1 “Fluorescent lamp fixtures for facilities” specified in the Japanese Industrial Standard C 8106 or fluorescent lamps having fluorescent lamp fixtures of high frequency lighting dedicated type	75
2 Fluorescent lamps other than the above-mentioned	62

2. Displays

2-1 Displays

Manufacturers shall display the following matters regarding the energy consumption efficiency of fluorescent lamps (Fluorescent lamp fixtures for desk top stand of the attached table item 1 No.3 (25) in the enforcement decree of the household goods labelling law (Cabinet order No.390 in 1962) are excluded.)

- a) Product name or model name of fluorescent lamp fixtures
- b) Forms of fluorescent lamps
- c) Total luminous flux
- d) Power consumption
- e) Energy consumption efficiency
- f) Name of manufacturers

2-2 Compliance matters

- (1) In total luminous flux, the numerical value measured by the method specified in 3 shall be displayed in lumen unit.
- (2) In power consumption, the numerical value measured by the method specified in input of 9.6 in the Japanese Industrial Standard C8105 shall be displayed in watt unit.

- (3) In the energy consumption efficiency, the numerical value enumerated in the 3rd lower column of the attached table in the law enforcement rules (the ordinance of the Ministry of International Trade and Industry No.74 in 1979) related to rationalization of the use of energy shall be displayed up to the first decimal place.
- (4) The display of the display matters enumerated in 2-1 shall be described on the catalog as to “Fluorescent lamp fixtures for facilities” or “Fluorescent lamps having fluorescent lamp fixtures of high frequency lighting dedicated type” specified in the Japanese Industrial Standard C8106, or as to “Fluorescent lamps other than the above-mentioned”, the display shall be described on the catalog and the main body of fluorescent lamp fixtures or on the places where it is easily viewable with not easily erased method.
(MITI notification 7 in 1995, partially revised)

3. Measurement methods of total luminous flux

In calculating the energy consumption efficiency, measurement of total luminous flux shall be made according to the method specified in the initial characteristics test of Japanese Industrial Standard C7601 except for the following matters.

- (1) Ambient temperature shall be $25\pm 3^{\circ}\text{C}$.
- (2) Fluorescent lamps of the relevant fluorescent lamp and the fluorescent lamp fixtures shall be used.
- (3) Measurement shall be made on the condition of connecting to lead wire after taking out the fluorescent lamp from the fluorescent lamp fixtures.
- (4) As to the circular type fluorescent lamp, when it is determined from the horizontal luminous intensity, it shall be the total luminous flux by taking the value of 9.3 times of the average horizontal luminous intensity.

However, applying the rated voltage of the rated frequency to the fluorescent lamp fixtures, then lighting up the fluorescent lamp for approximately 15 minutes, and after the properties become same, the average horizontal luminous intensity shall be the average value of the horizontal luminous intensity measured after installing the receiving light device at the place apart from more than 4 times distances of the outer diameter of the lamp on the vertical line against the surface including an annular ring passing through the center of the annular ring and at the place having turned this 180° setting a straight line passing through the center of the annular ring against the surface including the annular ring as an axis.

- (5) As to the compact type fluorescent lamp, when determining from the horizontal luminous intensity, after measuring the average horizontal luminous intensity at the same condition as to the fluorescent lamp measured by the total luminous flux using the sphere photometer, it shall be regarded as total luminous flux taking the calculated value setting this as a standard.

However, applying the rated voltage of the rated frequency to the fluorescent lamp fixtures, then lighting up the fluorescent lamp for approximately 45 minutes, and after the properties become same, the average horizontal luminous intensity shall be the average value of the horizontal luminous intensity measured after installing the receiving light device at the following specified place according to the forms.

- 1) In the case of type P, type M and type W, measurement shall be made at places apart from more than 4 times distances of length of the light generation part of fluorescent lamps on the vertical line against the front of the fluorescent lamp passing through the center part of the light generation part of the fluorescent lamp setting the base part to the upper part, and at places turning 180° against the center part of the fluorescent lamp.
- 2) In the case of type D, measurement shall be made at places apart from more than 4 times distances of length of the light generation part of fluorescent lamps on the vertical line against the front of the fluorescent lamp passing through the center part of the light generation part of the fluorescent lamp setting the base part to the upper part, and at places turning this at 90° , 180° and 270° setting the center line of the fluorescent lamp as an axis.

Supplementary provisions

This notification becomes effective from the date of decree. However, the rules of 2 will become effective from June 1, 1997.



Fluorescent lamps for general lighting service

C7601-1997

Foreword This standard is the Japanese Industrial Standard prepared based on IEC81, Tubular fluorescent lamps for general lighting service published as the 4th edition in 1984 and Amendment 5 (1994), and IEC 901, Single-capped fluorescent lamps- Safety and performance requirements published as the 2nd edition in 1987 and Amendment 2 (1992), and IEC 1195, Double-capped fluorescent lamps-Safety specifications published as the first edition in 1993, and IEC 1199, Single-capped fluorescent lamps – Safety specifications published as the first edition in 1993, but some deletions were made in relation to power supply voltage, etc. as to Lamp Data Sheet of IEC 81 and IEC 901.

1. Scope This standard specifies the striplight type, circular type fluorescent lamps and compact type fluorescent lamps (hereafter, called simply a lamp unless otherwise specified types and forms) for general lighting service lit up by AC circuits and dedicated high frequency lighting circuits (or the system).

Remarks 1. This standard contains the lamps indicated in the following.

- (1) Starter type for commercial frequency lighting with preheating type electrodes, it is also usable in high frequency lighting.
- (2) Rapid starter type for commercial frequency lighting with preheating type high resistant electrodes, it is also usable in high frequency lighting.
- (3) Rapid starter type for commercial frequency lighting with preheating type low resistant electrodes, it is also usable in high frequency lighting.
- (4) High frequency lighting type with preheating type electrodes.
- (5) Commercial frequency lighting type with non-preheating type electrodes.
- (6) High frequency lighting type with non-preheating type electrodes.
- (7) Starter built-in type with preheating type electrodes.

2. The following shows the referred standard in this standard.

JIS B 7507	Vernier caliper
JIS C 0073	Environmental test methods- Electric and electronic- fire resistance test Glow wire (pushing red heat bar) tests and guidelines for final products
JIS C 1102	Electrical indicating meter
JIS C 1302	Insulation-resistance meter
JIS C 1303	High insulation-resistance meter
JIS C 7603	Glow starter for fluorescent lamps
JIS C 7708	Glass tubes for fluorescent lamps
JIS C 7709-1	Caps and lamp holder of bulbs and those gauge and compatibility, safety The first part: cap
JIS C 7801	General rules for bulb test methods
JIS C 8108	Fluorescent lamp ballast
JIS C 8117	Fluorescent lamp electronic ballast
JIS C 8324	Fluorescent lamp socket and glow starter socket
JIS H 4541	Dumet wire
JIS Z 8113	Lighting terms

Furthermore, at this time, the cap must not have functional abnormalities.

5.3 Starting In starting, when the test was performed according to 9.3.5, the starter type fluorescent lamp starts in one minute or less, and must light up and maintain as it is. As to the rapid starter type fluorescent lamp and the slim line type fluorescent lamp, they start in 10 seconds or less, and the high frequency lighting dedicated type fluorescent lamp starts in 0.1 seconds or less, and must light up and maintain as it is.

- Remarks**
1. As to the starter type fluorescent lamp, the test is performed according to accompanying documents 4, and the lamp starts in 3 times or less and is desired to light up and maintain as it is.
 2. As to the compact type fluorescent lamp (Starter built-in), the test is performed according to accompanying documents 4, and the lamp starts in 10 seconds or less and is desired to light up and maintain as it is.
 3. As to the rapid start type fluorescent lamp and the slim line type fluorescent lamp, the test is performed according to accompanying documents 4, and the lamp starts in 10 seconds or less and is desired to light up and maintain as it is.
 4. As to the high frequency lighting dedicated fluorescent lamp, the test is performed according to accompanying documents 4, the lamp may start in five seconds or less for a while.

5.4 Initial characteristics When the test was performed according to 9.3.6, the initial characteristics must indicate 92% or more of the value \pm (Lamp wattage value \times 0.05+0.5) of the appendix table 1 in lamp wattage, the value of the appendix table 1 in lamp current and the value of the appendix table 1 in total luminous flux, respectively.

5.5 Light source color When the test was performed according to 9.3.7, the light source color must conform to the rules of chromaticity range in JIS Z 9112.

5.6 Operation property When the test was performed according to 9.3.8, the operation property must conform to the rules of the color rendering index in JIS Z 9112.

Furthermore, the three band area light generation type fluorescent lamp must conform to the rules of the three band area radiant flux ratio.

5.7 Cathode current The cathode current of the rapid start type fluorescent lamp and the high frequency lighting dedicated type fluorescent lamp must conform to the value of the appendix table 1 when the test was performed according to 9.3.9.

5.8 Lumen maintenance factor When the test was performed according to 9.3.10, the lumen maintenance factor must conform to the value of the appendix table 1.

5.9 High output lighting characteristics The high output lighting characteristics of the striplight type high frequency lighting dedicated type fluorescent lamp must conform to the value of the appendix table 1 when the test was performed according to 9.3.11.

5.10 Shatterproof film strength In the shatterproof film strength of the shatterproof type fluorescent lamp, the shatterproof film must not break when the test was performed according to 9.3.13.

5.11 Shatter-resistance In the shatter-resistance of the shatterproof type fluorescent lamp, broken glass must not fly in the outside circle in the radius (Length of lamp +1m) from almost the center of the lamp when the test was performed according to 9.3.14.

5.12 Cap part withstand voltage property In the cap part withstand voltage property, the metal-make cap body and pins or the insulation between conductive parts withstand the test voltage, and must not generate the dielectric breakdown during testing when the test was performed according to 9.3.15. However, this test is not applicable to the lamp of the cap having the inner resistor.

5.13 Cap part insulation property In the cap part insulation property, the insulation resistance between metal-make cap body and pins or conductive parts must not be lower than 0.5M Ω when the test was performed according to 9.3.16.

5.14 Cap part insulation heat-resistant property In the cap part insulation heat-resistant property, the changes which impair safety of looseness, cracks, expansion and contraction of cap pins must not occur when the test was performed according to 9.3.17.

Also, the cap after testing must conform to the cap dimension standard of the completed lamp specified in JIS C 7709-1 and must conform to the electrical test specified in 5.12 and 5.13.

5.15 Cap temperature rise of lamps In the lamp with C5 and C13 cap, the temperature rise portion exceeding the ambient temperature of cap parts must not exceed 95 K when the test was performed according to 9.3.18.

Furthermore, If the cap temperature rise of some lamp groups is the maximum in the specific lamp model like the lamp of nominal 26 mm glass tube diameter, the test is performed only in its lamp group, and the test for lamps with all other same diameter caps is omitted.

(...), the start support shall not be used in the case of the compact type fluorescent lamp.

4. Metal part other than necessary starter device shall locate away from the lamp as much as possible.
5. As to the high frequency lighting dedicated type fluorescent lamp, the test may be made by the test method of accompanying documents 3.

- (4) **Slim line type fluorescent lamp** The test is made applying the starting test voltage indicated in the appendix table 1 using the ballast for tests indicated in the appendix table 2. As to the lamp which will not start by this test, try to start rising gradually up to 125% of the start test voltage, and after lighting up the started lamp for 30 minutes by the rated input voltage of the ballast using the ballast specified in JIS C 8108, and leave the lamp with no lighting up for more than 24 hours, and perform the above-mentioned test again.

9.3.6 Initial characteristics test In initial characteristics, the aged lamp for 100 hours with the rated input voltage of the ballast using the ballast specified in JIS C 8108 or accompanying documents 1 is connected like the attached drawing 2 using the ballast for tests indicated in the appendix table 2 in Draught free environment at ambient temperature $25\pm 1^{\circ}\text{C}$, and in the case of striplight and circular type fluorescent lamps, after the characteristics become almost same lighting up for approximately 15 minutes, and in the case of the compact type fluorescent lamp, after the characteristics become almost same lighting up for 45 minutes or more, the lamp wattage, the lamp current, the lamp voltage and total luminous flux are measured.

Furthermore, input voltage and cathode preheating voltage are subject to the following.

- (1) **Starter type fluorescent lamp** The rated input voltage indicated in the appendix table 1 is applied.
- (2) **Rapid start type fluorescent lamp** Set the secondary side of the main circuit transformer as the rated input voltage indicated in the appendix table 1, and apply cathode preheating voltage 3.6 V. The measurement of the lamp wattage, the lamp current, the lamp voltage and total luminous flux is made opening the cathode preheating circuit. However, as to the lamp with G13 cap, the test may be made with the starter type lamp circuits.
- (3) **High frequency lighting dedicated type fluorescent lamp** Set the secondary side of the main circuit transformer as the rated input voltage indicated in the appendix table 1, and apply cathode preheating voltage 7.0 V. The measurement of the lamp wattage, the lamp current, the lamp voltage and total luminous flux is made opening the cathode preheating circuit.
- (4) **Slim line type fluorescent lamp** Apply the rated input voltage indicated in the appendix table 1. Furthermore, unless otherwise specified, the measurement is made only in the case of the standard use (¹), and the measurement of the lamp wattage is not performed.

Note (¹) The standard use of the slim line type lamp means that the central value of the lamp current is 0.2 A.

- Remarks**
1. Fluctuations of power supply voltage during aging for 100 hours shall be $\pm 2\%$, and the lighting up method is subject to the rules of 4.4 of JIS C 7801 (Life test).
 2. Measurement of voltage and current effective value and electric power is measured using the instrument over the grade of Class 0.5 specified in JIS C 1102 or the equivalent or more instrument in accuracy. However, the voltmeter for measuring cathode preheating voltage of the rapid start type lamp shall be Class 1.0 or more.
Furthermore, impedance of voltage circuit of the instrument connected in parallel with the lamp shall be enough to be high so that its effective shunt current becomes 3% or less of the lamp current.
In addition, impedance of current circuit of the instrument connected in series with the lamp shall be enough to be low so that its voltage drop becomes 2% or less of the lamp voltage. However, measurement of the lamp with 10W or less is not applied.
 3. Measurement of total luminous flux is subject to the following.
 - (1) As a principle, measure it by using the sphere photometer. In this case, the inner diameter of the integrating sphere shall be 1.2 times or more of the lamp's length.
 - (2) When determining from the horizontal luminous intensity, the value of total luminous flux shall be the value of 9.3 times of the average horizontal luminous intensity. However, the average horizontal luminous intensity is the average value of luminous intensity of the vertical direction against the lamp axis passing through the central part of the lamp, and its measurement is as principle made at 4 times or more distances of the length of the lamp. However, this method is not applied to the ones other than striplight types.
 4. In the temperature other than the ambient temperature of $25\pm 1^{\circ}\text{C}$, when measuring the lamp wattage, the lamp current, the lamp voltage and total luminous flux, the measurement is made at the temperature range of $20\text{-}27^{\circ}\text{C}$, and provide the temperature correction about these measured value.

Appendix table 1 Dimension, cap and characteristics

1. Starter type

(a) Striplight type

Types	Classification of size	Rated lamp wattage W	Dimension mm					Cap	
			A	B		C			D
			Maximum value	Standard value	Maximum value	Minimum value	Maximum value		
FL4	4	4	135.9	134.5	143.0	140.6	150.1	G5	15.5±0.6
FL6	6	6	212.1	210.5	219.2	216.8	226.3		
FL8	8	8	288.3	287.0	295.4	293.0	302.5		
FL10	10	10	331.3	330.0	338.4	336.0	345.5	G13	25.5±1.2
FL15	15	15	437.4	436.0	444.5	442.1	451.6		
FL20SS/18	20	18	581.3	580.0	588.4	586.0	595.5	28.0±1.5	32.5±1.5
FL20S		20							
FL30S	30	30	631.3	630.0	638.4	636.0	645.5	32.5±1.5	
FL40SS/37	40	37	1,199.4	1,198.0	1,206.5	1,204.1	1,213.6	28.0±1.5	32.5±1.5
(FL40SS/38)		38							
FL40S		40							

Remarks: Cap dimension is subject to JIS C 7709-1.

- Reference**
1. FL20, FL30, FL40 are the discontinued items.
 2. The lamp with () will be the discontinued items in the future.

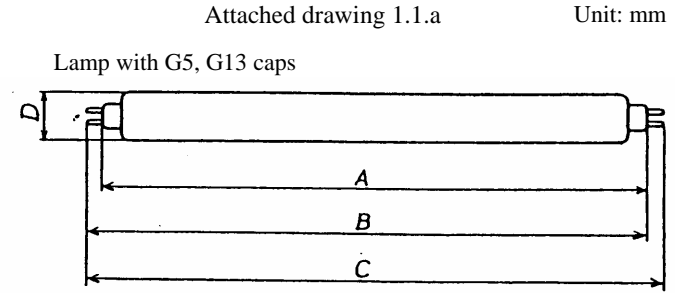

Cap pin part
In the case of weld or caulking

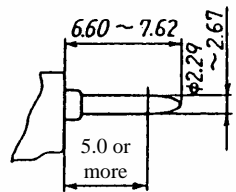

VI-42

Appendix table 1 Dimension, cap and characteristics (Continued)

Types	Classification of size	Rated lamp wattage	Rated input voltage	Start test voltage	Initial characteristics									Lumen maintenance factor	(Reference) Rated life
					Lamp wattage	Lamp current	(Reference) Lamp voltage	Total luminous flux lm							
								D	N	W, WW, L	EX-D	EX-N	EX-W, WW-L		
W	A	V								%	h				
FL4	4	4	100	94	4.6	0.162±0.020	30	(90)	(95)	(100)	-	-	-	-	2400 or more
FL6	6	6	5.9		0.147±0.020	44	(155)	(170)	(180)	-	-	-	-		
FL8	8	8	7.9		0.170±0.020	56	(260)	(280)	(290)	-	-	-	-		
FL10	10	10	9.5		0.230±0.030	46	410	440	460	490	530	540	75 or more	4000 or more	
FL15	15	15	14.7		0.300±0.030	55	710	780	820	860	920	940			
FL20SS/18	20	18	18.0		0.340±0.040	59	1010	1100	1160	1320	1400	1430	85 or more	6000 or more	
FL20S		20	19.0		0.360±0.040	58									
FL30S	30	30	30.0		0.610±0.050	55	1480	1620	1700	1790	1900	1940	75 or more		
FL40SS/37	40	37	200	180	37.0	0.410±0.040	108	2610	2850	3000	3180	3380	3450	85 or more	8000 or more
(FL40SS/38)		38			38.0	0.410±0.040	109								
FL40S		40			39.5	0.420±0.040	106								

- Remarks**
1. The value attaching () to the value of total luminous flux shall be the reference value.
 2. Total luminous flux of -DL, -SDL and -EDL in color rendering property classification shall be 75% or more, 65% or more and 60% or more of this table's value respectively.
 3. Total luminous flux of shatterproof types shall be 97% or more of this table's value.
 4. Lumen maintenance factor of -DL, -SDL and -EDL in color rendering property classification shall be more than the value deducting 5 from this table's value.

Appendix table 1 Dimension, cap and characteristics (Continued)

(b) Circular type

Types	Classification of size	Rated lamp wattage W	Dimension mm				Cap
			A		B	C	
			Maximum value	Standard value	Minimum value	Maximum value	
FCL20/18	20	18	153	147	141	213	G10q
FCL30/28	30	28	173	167	161	233	
FCL32/30	32	30	247	241	235	307	
FCL40/38	40	38	321	315	309	381	

Attached drawing 1.1.b

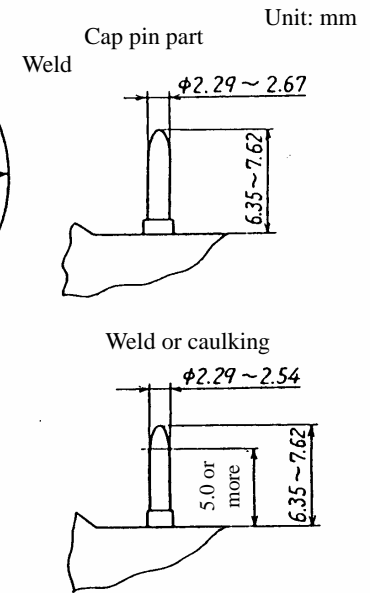
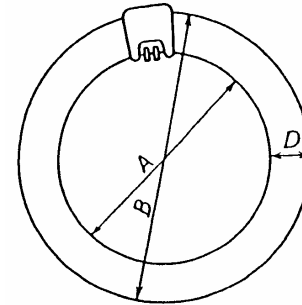

Remarks: Cap dimension is subject to JIS C 7709-1.

Reference FCL20, FCL30, FCL32, FCL40 are the discontinued items.

Types	Classification of size	Rated lamp wattage W	Rated input voltage V	Start test voltage V	Initial characteristics									Lumen maintenance factor %	(Reference) Rated life h
					Lamp wattage W	Lamp current A	(Reference) Lamp voltage V	Total luminous flux lm							
								D	N	W, WW, L	EX-D	EX-N	EX-W, WW-L		
FCL20/18	20	18	100	94	18	0.365±0.040	58	900	1510	1040	1170	1240	1270	70 or more	4000 or more
FCL30/28	30	28			28	0.600±0.050	55	1370	1860	1580	1880	2000	2040		
FCL32/30	32	30	147	137	30	0.425±0.040	83	1690	2550	1940	2240	2380	2430		
FCL40/38	40	38	200	180	38	0.425±0.040	103	2310		2660	2920	3110	3170		

Remarks: Lumen maintenance factor of -DL, -SDL and -EDL in color rendering property classification shall be 75% or more, 65% or more and 60% or more of this table's value respectively.

Appendix table 1 Dimension, cap and characteristics (Continued)

(c) Compact type: type P lamp (Two tubes type)

Types	Rated lamp wattage	Dimension mm			Cap
		A	B	C	
	W	Maximum value	Maximum value	Maximum value	
FPL4	4	36	17	95	GX10q-1
FPL6	6			116	
FPL9	9			141	
FPL13	13			186	GX10q-2
FPL18	18	46	21	226	GY10q-3
FPL27	27	46	21	265	GY10q-4
FPL30	30	54	25	285	
FPL28	28	46	21	340	GY10q-5
FPL36	36			435	GY10q-6
FPL55	55			570	GY10q-7

Attached drawing 1.1.e (type P)

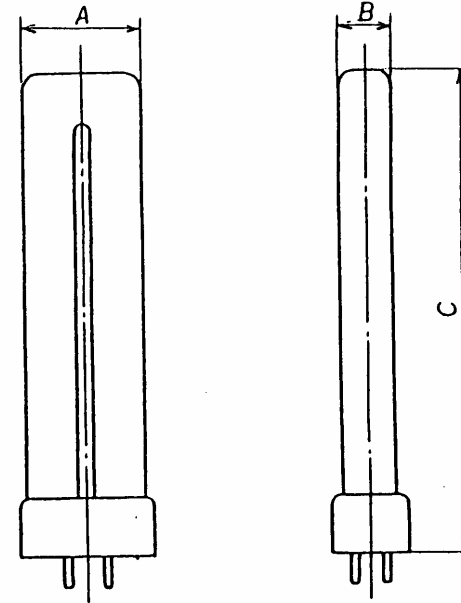

- Remarks**
1. Cap dimension is subject to JIS C 7709-1.
 2. Dimension of cap pin part is pursuant to G10q (Attached drawing 1.1.b).

Appendix table 1 Dimension, cap and characteristics (Continued)

Types	Rated lamp wattage W	Rated input voltage V	Start test voltage V	Initial characteristics						Lumen maintenance factor %	(Reference) Rated life h
				Lamp wattage W	Lamp current A	(Reference) Lamp voltage V	Total luminous flux lm				
							EX-D	EX-N	EX-W, WW, L		
FPL4	4	100	94	4.0	0.162±0.020	33	170	180	180	75 or more	3000 or more
FPL6	6			6.0	0.147±0.020	40	280	300	300		4000 or more
FPL9	9			9.0	0.230±0.030	44	490	520	520		
FPL13	13			13.0	0.300±0.030	54	750	800	800		
FPL18	18			18.0	0.375±0.040	57	1000	1070	1070		6000 or more
FPL27	27			27.0	0.610±0.050	54	1610	1700	1700		
FPL30	30			29.0	0.620±0.050	55	1790	1900	1900		
FPL28	28	147	137	28.4	0.425±0.040	80	1880	2000	2000		
FPL36	36	200	180	36.0	0.435±0.040	102	2590	2760	2760		
FPL55	55			55.0	0.670±0.060	109	4000	4200	4200		

Appendix table 1 Dimension, cap and characteristics (Continued)

(c) Compact type: type D lamp (4 tubes type)

Types	Rated lamp wattage	Dimension mm			Cap
		A	B	C	
	W	Maximum value	Maximum value	Maximum value	
FDL9	9	39	39	105	GX10q-1
FDL13	13			120	GX10q-2
FDL18	18			129	GX10q-3
FDL27	27			145	GX10q-4

- Remarks**
1. Cap dimension is subject to JIS C 7709-1.
 2. Cap pin part dimension is pursuant to C10q (Attached drawing 1.1.b).

Attached drawing 1.1.e (type D)

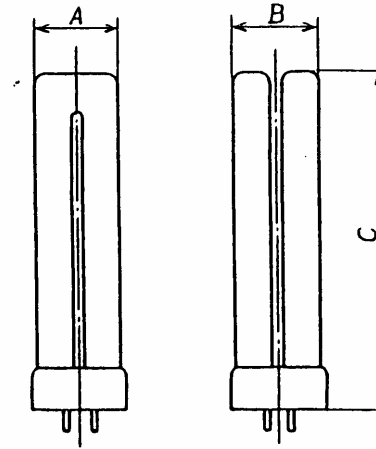

VI-47

Types	Rated lamp wattage	Rated input voltage	Start test voltage	Initial characteristics						Lumen maintenance factor	(Reference) Rated life
				Lamp wattage	Lamp current	(Reference) Lamp voltage	Total luminous flux lm				
							W	A	V		
FDL9	9	100	94	9.3	0.230±0.030	53	470	500	500	75 or more	5000 or more
FDL13	13			13.3	0.300±0.030	54	710	760	760		
FDL18	18			17.5	0.375±0.040	55	950	1010	1010		
FDL27	27			26.8	0.610±0.050	56	1380	1470	1470		

C7601-1997

Appendix table 1 Dimension, cap and characteristics (Continued)

(c) Compact type: type M lamp (4 tubes type)

Types	Rated lamp wattage W	Dimension mm			Cap
		A	B	C	
		Maximum value	Maximum value	Maximum value	
FML9	9	81	18.5	106	GX10q-1
FML13	13			125	GX10q-2
FML18	18			135	GX10q-3
FML27	27			147	GX10q-4
FML36	36	96	21	252	GX10q-6

Attached drawing 1.1.c (type M)

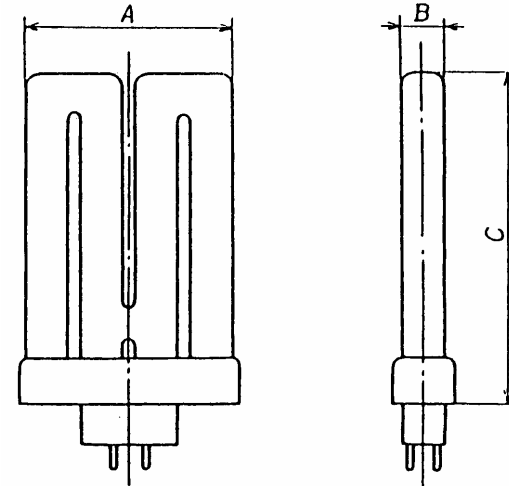

- Remarks**
1. Cap dimension is subject to JIS C 7709-1.
 2. Cap pin part dimension is pursuant to C10q (Attached drawing 1.1.b).

VI-48

Types	Rated lamp wattage W	Rated input voltage V	Start test voltage V	Initial characteristics						Lumen maintenance factor %	(Reference) Rated life h
				Lamp wattage W	Lamp current A	(Reference) Lamp voltage V	Total luminous flux lm				
							EX-D	EX-N	EX-W, WW, L		
FML9	9	100	94	9.3	0.230±0.030	53	490	520	520	75 or more	5000 or more
FML13	13			13.5	0.300±0.030	54	750	800	800		
FML18	18			17.5	0.375±0.040	55	980	1040	1040		
FML27	27			26.8	0.610±0.050	56	1410	1500	1500		
FML36	36	200	180	36.0	0.435±0.040	105	2590	2760	2760		

Appendix table 1 Dimension, cap and characteristics (Continued)

(c) Compact type: type W lamp (4 tubes type)

Types	Rated lamp wattage	Dimension mm			Cap
		A	B	C	
	W	Maximum value	Maximum value	Maximum value	
FWL9	9	81	18.5	96	GX10q-1
FWL13	13			115	GX10q-2
FWL18	18			121	GX10q-3
FWL27	27			129	GX10q-4
FWL36	36	96	21	226	GX10q-6

Attached drawing 1.1.c (type W)

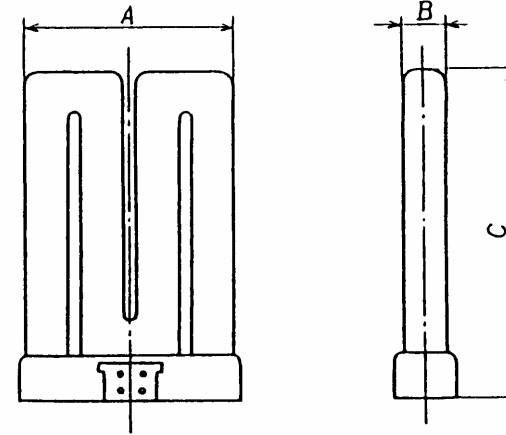

- Remarks**
1. Cap dimension is subject to JIS C 7709-1.
 2. Cap pin part dimension is pursuant to C10q (Attached drawing 1.1.b).

VI-49

Types	Rated lamp wattage	Rated input voltage	Start test voltage	Initial characteristics						Lumen maintenance factor	(Reference) Rated life
				Lamp wattage	Lamp current	(Reference) Lamp voltage	Total luminous flux lm				
							W	A	V		
FWL9	9	100	94	9.3	0.230±0.030	53	490	520	520	75 or more	5000 or more
FWL13	13			13.5	0.300±0.030	54	750	800	800		
FWL18	18			17.5	0.375±0.040	55	980	1040	1040		
FWL27	27			26.8	0.620±0.050	56	1410	1500	1500		
FWL36	36	200	180	36.0	0.435±0.040	105	2590	2760	2760		

C7601-1997

Appendix table 1 Dimension, cap and characteristics (Continued)

(c) Compact type: type PX lamp (Starter built-in 2 pieces tubes type)

Types	Rated lamp wattage	Dimension mm			Cap
		A	B	C	
	W	Maximum value	Maximum value	Maximum value	
FPX5	5	28	13	85	G23
FPX7	7			115	
FPX9	9			145	
FPX11	11			215	
FPX13	13			170	GX23

Attached drawing 1.1.c (type PX)

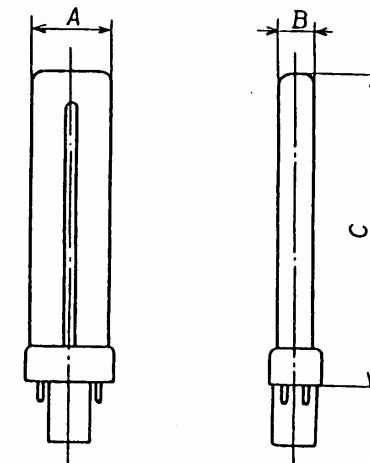

- Remarks**
1. Cap dimension is subject to JIS C 7709-1.
 2. Cap pin part dimension is pursuant to C10q (Attached drawing 1.1.b).

Types	Rated lamp wattage	Rated input voltage	Start test voltage	Initial characteristics						Lumen maintenance factor	(Reference) Rated life
				Lamp wattage	Lamp current	(Reference) Lamp voltage	Total luminous flux lm				
							W	A	V		
FPX5	5	220	198	5.4	0.180±0.020	35	240	240	240	75 or more	5000 or more
		(100)	(90)	(5.5)	(0.180±0.020)						
FPX7	7	220	198	6.9	0.180±0.020	45	380	380	380		
		(100)	(90)	(7.0)	(0.180±0.020)						
FPX9	9	220	198	8.7	0.170±0.020	60	570	570	570		
		(118)	(106)	(9.0)	(0.180±0.020)						
FPX11	11	220	198	11.4	0.155±0.020	90	860	860	860		
FPX13	13	118	106	13.4	0.285±0.030	59	860	860	860	6000 or more	

Remarks: The numerical value of () shall be the reference value.

Appendix table 1 Dimension, cap and characteristics (Continued)

(c) Compact type: DX type lamp (Starter built-in 4 pieces tubes type)

Types	Rated lamp wattage	Dimension mm			Cap
		A	B	C	
	W	Maximum value	Maximum value	Maximum value	
FDX10	10	28	28	95	G24d-1
FDX13	13			130	
FDX18	18			150	G24d-2
FDX26	26			170	

- Remarks**
1. Cap dimension is subject to JIS C 7709-1.
 2. Cap pin part dimension is pursuant to C10q (Attached drawing 1.1.b).

Attached drawing 1.1.c (DX type)

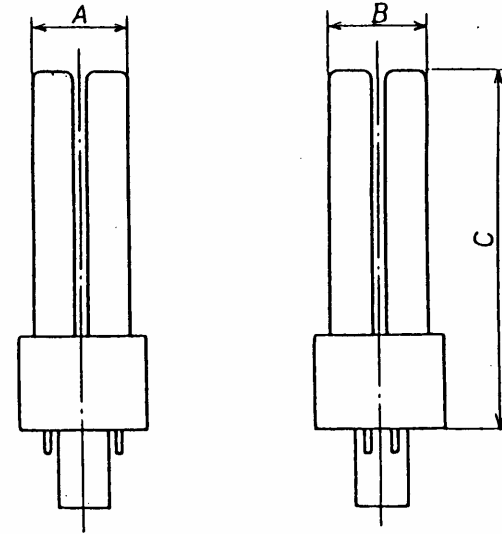

VI-51

Types	Rated lamp wattage	Rated input voltage	Start test voltage	Initial characteristics						Lumen maintenance factor	(Reference) Rated life
				Lamp wattage	Lamp current	(Reference) Lamp voltage	Total luminous flux lm				
							W	A	V		
FDX10	5	220	198	10.0	0.190±0.020	67	570	570	570	75 or more	5000 or more
FDX13	7			13.0	0.165±0.020	100	860	860	860		
FDX18	9			18.0	0.220±0.020	105	1140	1140	1140		
FDX26	11			26.0	0.315±0.030	110	1710	1710	1710		

C7601-1997

Appendix table 1 Dimension, cap and characteristics (Continued)

2. Rapid start type

Types	Classification of size	Rated lamp wattage	Dimension mm							Cap
			A		B		C		D	
			Maximum value	Standard value	Maximum value	Minimum value	Maximum value	Minimum value		
FLR20S	20	20	581.3	580.0	588.4	586.0	595.5	-	32.5±1.5	G13
FLR40/36	40	36	1199.4	1198.0	1206.5	1204.1	1213.6	-	32.5±1.5	
FLR40S		40								
FLR110H/100	110	100	-	2367.0	-	-	2385.2	2380.4	38.0±1.5	R17d
FLR110H		110								

Attached drawing 1.2

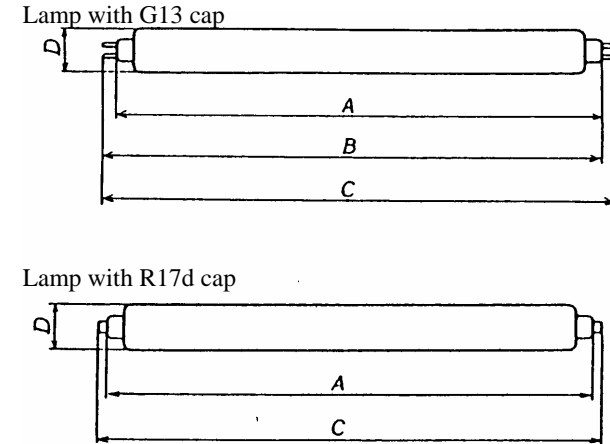

- Remarks**
1. Cap dimension is subject to JIS C 7709-1.
 2. Pin part dimension of G13 cap is pursuant to the attached drawing 1.1.a.

Reference FLR20 and FLR40 is the discontinued product class.

Types	Classification of size	Rated lamp wattage	Cathode current (In 3.6 V)	Preheating voltage in the start test	Rated input voltage	Start test voltage	Initial characteristics									Lumen maintenance factor	(Reference) Rated life		
							Lamp wattage	Lamp current	(Reference) Lamp voltage	Total luminous flux lm									
										D	N	W, WW, L	EX-D	EX-N	EX-W, WW-L				
FLR20S	20	20	0.5 or less	3.05	155	140	19.0	0.360±0.040	58	960	1050	1100	1080	1150	1170	75 or more	6000 or more 8000 or more		
FLR40/36	40	36					230	205	36.0	0.440±0.040	96	2560	2700	2850	3080			3280	3350
FLR40S		40							39.5	0.420±0.040	106								
FLR110H/100	110	100	1.2 or less		400	360	100.0	0.820±0.050	142	7570	8260	8700	8580	9130	9310				
FLR110H		110							109.0									0.800±0.050	159

- Remarks**
1. Total luminous flux of -DL, -SDL and -EDL in color rendering property classification shall be 75% or more, 65% or more and 60% or more of this table's value respectively.
 2. Total luminous flux of shatterproof types shall be 97% or more of this table's value.
 3. Lumen maintenance factor of -DL, -SDL and -EDL in color rendering property classification shall be more than the value deducting 5 from this table's value.

Appendix table 1 Dimension, cap and characteristics (Continued)

3. High frequency lighting dedicated type

(a) Striplight type

Types	Classification of size	Rated lamp wattage	Dimension mm					Cap	
			A		B		C		D
			Maximum value	Standard value	Maximum value	Minimum value	Maximum value		
FHF16	20	16	589.8	588.5	596.9	594.5	604.0	25.5±1.2	G13
FHF32	40	32	1199.4	1198.0	1206.5	1204.1	1213.6		
FHF50	65	50	1500.0	1498.5	1507.1	1504.7	1514.2		

Attached drawing 1.3.a

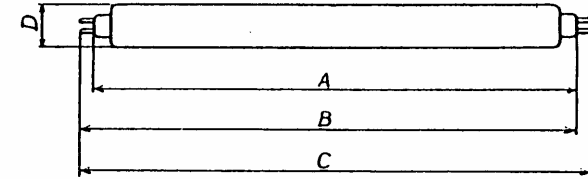

- Remarks**
1. Cap dimension is subject to JIS C 7709-1.
 2. Cap pin part dimension is pursuant to C13 (Attached drawing 1.1.a).

Rated characteristics

Types	Rated lamp wattage	Cathode current	Cathode preheating voltage in the start test	Rated input voltage	Start test voltage	Initial characteristics						Lumen maintenance factor	(Reference) Rated life
						Lamp wattage	Lamp current	(Reference) Lamp voltage	Total luminous flux lm				
									EX-D	EX-N	EX-W, WW, L		
W	A	V	V	V	W	A	V	EX-D	EX-N	EX-W, WW, L	%	h	
FHF16	16	0.51±0.05	6.0	128	200	16.2	0.255±0.030	64	1250	1330	1360	80 or more	8000 or more
FHF32	32	0.51±0.05		256	240	32.4	0.255±0.030	128	2860	3040	3100		
FHF50	50	0.56±0.05		284	280	50.4	0.355±0.040	142	4650	4940	5040		

High output lighting characteristics

FHF16	-	-	-	128	-	23.0	0.425±0.050	54	1790	1900	1940	80 or more	8000 or more
FHF32	-	-		256	-	45.3	0.425±0.050	107	4030	4280	4370		
FHF50	-	-		284	-	65.4	0.500±0.060	119	5720	6080	6200		

- Remarks**
1. The lighting frequency shall be 45 kHz.
 2. The start voltage test is indicated on the condition of one side ground power supply pursuant to IEC 81.

Appendix table 1 Dimension, cap and characteristics (Continued)

(b) Compact type: type H lamp (High frequency lighting dedicated 6 tubes type)

Attached drawing 1.3.b

Types	Rated lamp wattage	Dimension mm			Cap
		A	B	C	
	W	Maximum value	Maximum value	Maximum value	
FHT16	16	52	52	105	GX24q-2
FHT24	24	52	52	125	GX24q-3
FHT32	32	52	52	140	GX24q-3

- Remarks**
1. Cap dimension is subject to JIS C 7709-1.
 2. Cap pin part dimension is pursuant to G10q (Attached drawing 1.1.b).

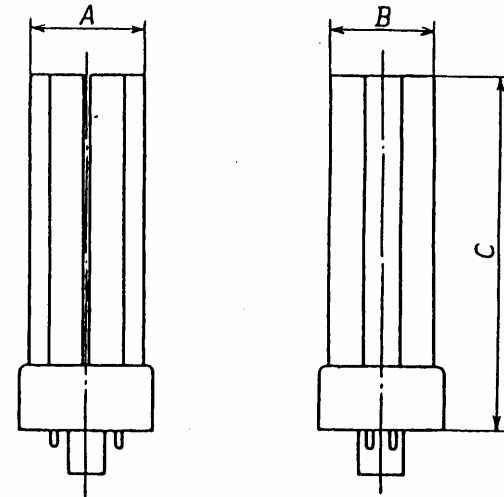

VI-54

Types	Rated lamp wattage	Cathode current	Cathode preheating voltage in the start test	Rated input voltage	Start test voltage	Initial characteristics						Lumen maintenance factor	(Reference) Rated life
						Lamp wattage	Lamp current	(Reference) Lamp voltage	Total luminous flux lm				
									W	A	V		
FHT16	16	0.22±0.02	6.0	160	400	16.5	0.210±0.020	80	1040	1100	1100	70 or more	5000 or more
FHT24	24	0.36±0.04	4.0	200	420	24	0.300±0.030	80	1600	1700	1700		
FHT32	32				440	32	0.320±0.030	100	2160	2300	2300		

- Remarks**
1. The lighting frequency shall be 45 kHz.
 2. The start voltage test is indicated on the condition of one side ground power supply pursuant to IEC 81.

Appendix table 1 Dimension, cap and characteristics (Continued)

4. Slim line type

Types	Dimension mm			D	Cap
	A				
	Maximum value	Standard value	Minimum value		
FSL30T6	695	692	689	20.1±1.2	FaX6
FSL42T6	1002	999	996		
FSL54T6	1305	1302	1299		
FSL64T6	1559	1556	1553		

Attached drawing 1.4

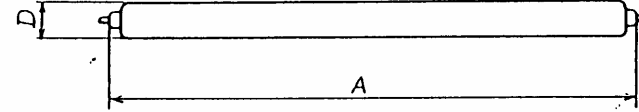

Remarks Cap dimension is subject to JIS C 7709-1.
Reference FSL72T8 and FSL96T8 are the discontinued product class.1.1.b).

Types	Rated input voltage V	Start test voltage V	Initial characteristics									Lumen maintenance factor %	(Reference) Rated life h
			Lamp wattage W	Lamp current A	(Reference) Lamp voltage V	Total luminous flux lm							
						D	N	W, WW, L	EX-D	EX-N	EX-W, WW-L		
FSL30T6	450	405	13	0.12±0.01	121	680	730	770	790	850	870	70 or more	4000 or more
			18	0.20±0.02	105	1040	1120	1180	1220	1300	1330		
FSL42T6	600	540	17	0.12±0.01	174	960	1040	1090	1120	1200	1230		
			25	0.20±0.02	150	1480	1600	1680	1730	1850	1900		
FSL54T6	600	540	22	0.12±0.01	224	1290	1390	1460	1500	1610	1650		
			32	0.20±0.02	197	1980	2140	2250	2320	2480	2540		
FSL64T6	600	540	26	0.12±0.01	267	1550	1670	1760	1810	1940	1990		
			37	0.20±0.02	233	2380	2570	2700	2780	2970	3050		

Remarks

- Total luminous flux of -DL, -SDL and -EDL in color rendering property classification shall be 75% or more, 65% or more and 60% or more of this table's value respectively.
- Total luminous flux of shatterproof types shall be 97% or more of this table's value.
- Lumen maintenance factor of -DL, -SDL and -EDL in color rendering property classification shall be more than the value deducting 5 from this table's value.

Attached drawing 2 Test circuits
(1) Starter type

(a) Initial characteristics test circuits
Start test circuits

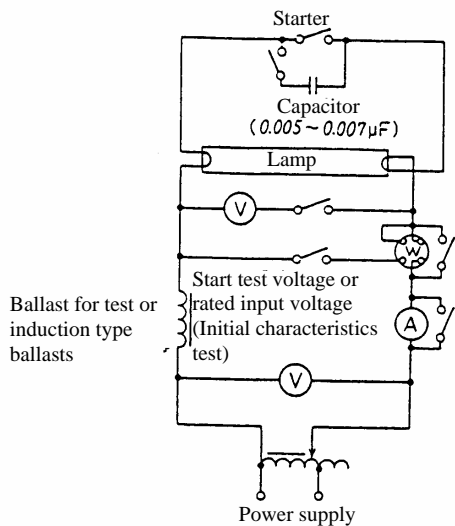

(b) Start test circuits

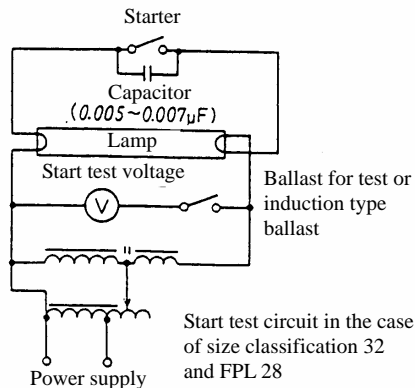

Remarks: Capacitors in parallel with the starter shall be only used when in the start test.

(2) Rapid start type

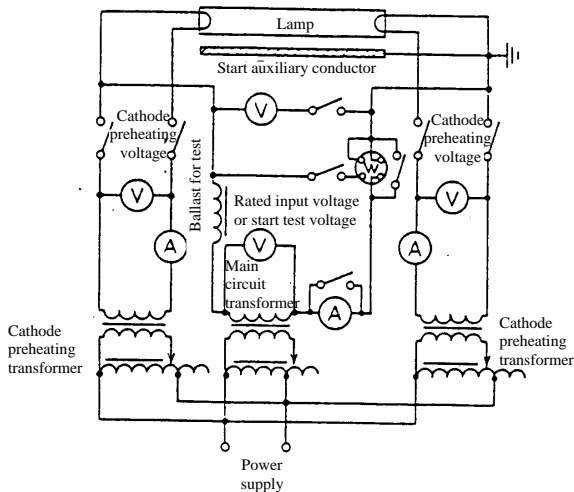

(3) Slim line type

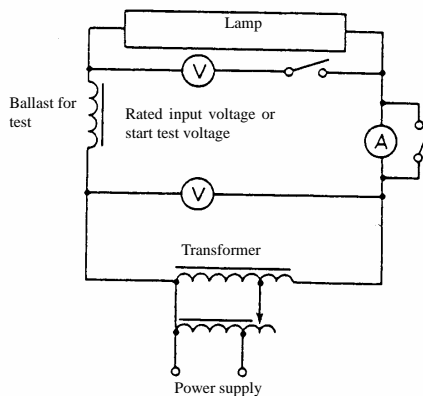

Remarks: When the symbol of the start auxiliary is the lamp of M, the start auxiliary conductor and grounds are excluded.

Attached drawing 2 Test Circuit (Continued)
 (1) High frequency lighting dedicated (F11F, FHT) type

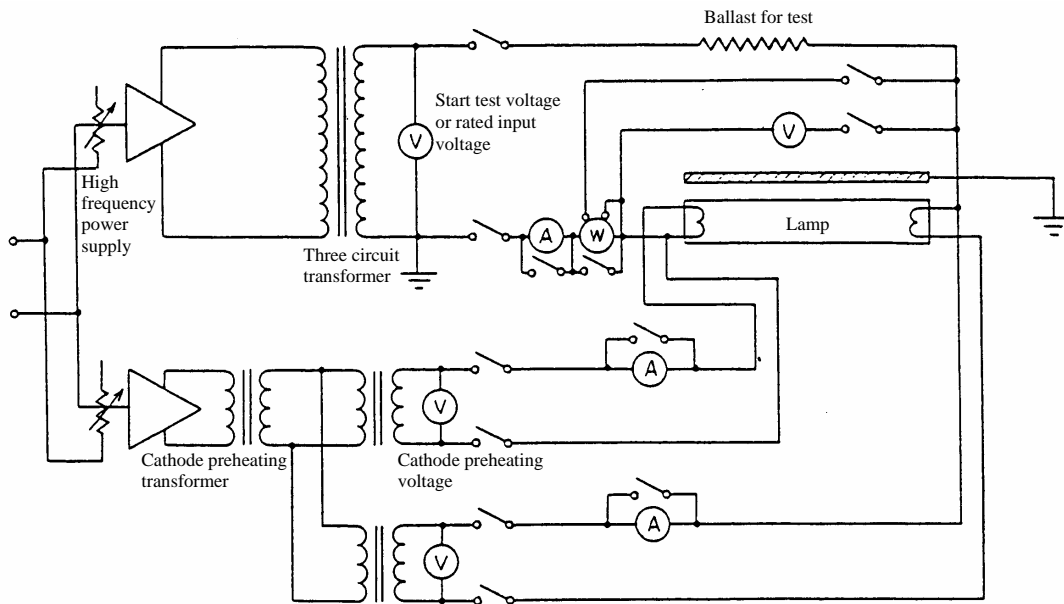

(5) Starter built-in type

(a) Initial characteristics test circuit

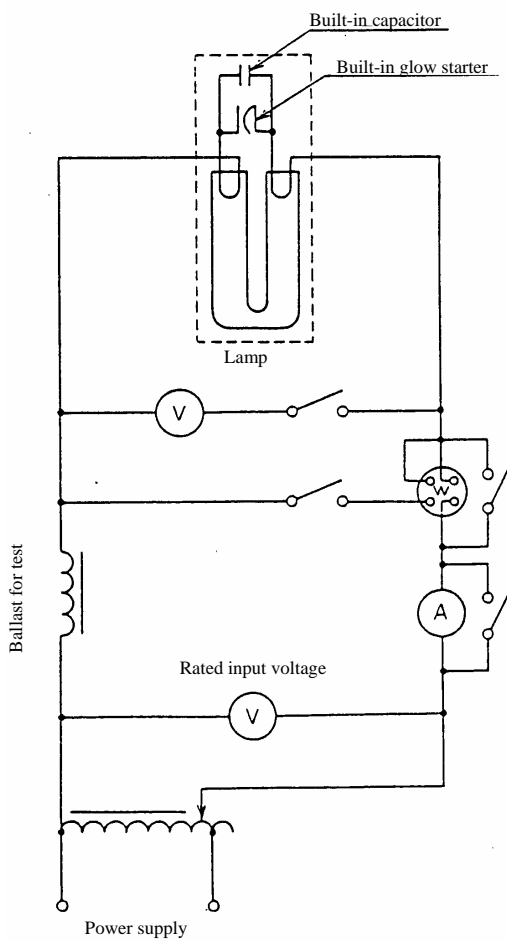

(b) Start test circuit

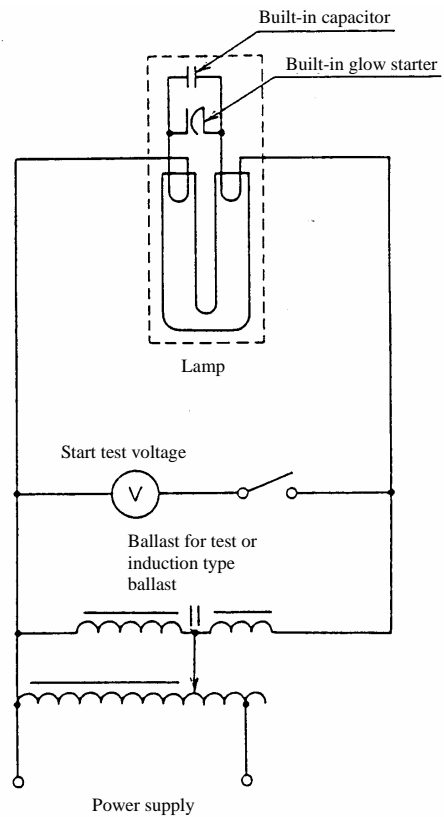

Attached table 2 Ballast for test

1. Starter type

Types of conformed lamps		Rated input voltage V	Reference current A	Impedance Ω	Power factor
FL4	FPL4	100	0.147	553±5	0.075±0.010
FL6	FPL6				
FL8			0.170	423±4	
FL10	FPL9 FDL9 FML9 FWL9	100	0.230	355±2	0.075±0.005
FL15	FPL13 FDL13 FML13 FWL13		0.300	244±1	
FL20 FL20SS/18	FCL20/18 FPL18 FDL18 FML18 FWL18		0.375	190±1	
FL30S	FCL30/28 FPL27 FDL27 FML27 FWL27 FPL30	100	0.620	118±1	0.075±0.005
	FCL32/30 FPL28		0.435	241±1	
FL40SS/37 (FL40S/38) FL40S	FCL40/38 FPL36 FML36 FWL36 FPL55		0.435	341±2	
			0.670	207±2	

2. High frequency lighting dedicated type

Types of conformed lamps	Lamp wattage W	Rated input voltage V	Reference current A	Direct current resistance Ω	Power factor
(a) Striplight type					
FHF16	Rating 16	128	0.255	250±2	0.99 or more
	High output 23		0.425	173±2	
FHF32	Rating 32	256	0.255	500±5	
	High output 45		0.425	350±2	
FHF50	Rating 50	284	0.355	400±3	
	High output 65		0.550	300±3	
(b) Compact type					
FHF16	Rating 16	160	0.210	380±3	0.99 or more
FHF32	Rating 24	160	0.300	265±2	
FHF50	Rating 32	200	0.320	315±3	

Attached table 2 Ballast for test (Continued)

3. Rapid start type

Types of conformed lamps	Rated input voltage V	Reference current A	Impedance Ω	Power factor
FLR20S	155	0.375	357±2	0.075±0.005
FLR40S/36, FLR40S	230	0.435	418±2	
FLR110H/100, FLR110H	400	0.800	413±2	

4. Slim line type

Types of conformed lamps	Rated input voltage V	Reference current A	Impedance Ω	Power factor
FSL30T6	450	0.120	3430±14	0.075±0.005
		0.200	2085±9	
FSL42T6		0.120	3200±13	
		0.200	1950±8	
FSL54T6	600	0.120	4220±17	
		0.200	2650±11	
FSL64T6		0.120	4175±17	
		0.200	2555±11	

5. Starter built-in compact type

Types of conformed lamps	Rated input voltage V	Reference current A	Impedance Ω	Power factor
FPX5	220	0.170	1180±10	0.12±0.02
	(100)	(0.180)	(450±5)	
FPX7	220	0.170	1180±10	
	(100)	(0.180)	(445±5)	
FPX9	220	0.170	1180±10	
	(118)	(0.180)	(515±5)	
FPX11	220	0.170	1180±10	
FPX13	118	0.285	325±2	0.075±0.005
FDX10	220	0.165	1070±0	0.12±0.02
FDX13		0.165	1070±10	0.12±0.02
FDX18		0.220	800±8	
FDX26		0.315	540±5	0.10±0.01

Remarks The numerical value in the bracket shall be the reference value.

Accompanying documents 1 (Rules)
Ballasts for high frequency lighting dedicated type fluorescent lamp

1. Scope This accompanying documents 1 specifies about the ballast used in a general place on the condition that the rated voltage is 300 V or less of 50 Hz, 60 Hz or 50 Hz/60 Hz in common use and the rated secondary voltage is 1000 V or less out of the electric ballast used in lighting of the high frequency lighting dedicated type fluorescent lamp.

Remarks The matters other than specified in this accompanying document 1 are subject to JIS C 8117.



2. Definition of terms

(1) **Rated lamp wattage output type ballasts** This is a ballast obtaining almost the same total luminous flux as the total luminous flux when the lamp was lit up with the ballast for tests of the rated lamp wattage specified in the main body attached drawing 2.

(2) **High output ballasts** This is a ballast obtaining almost the same total luminous flux as the total luminous flux when the lamp is lit up with the ballast for tests of the high output lamp wattage specified in the main body attached drawing 2.

3. Types Types are subject to the accompanying document 1 Table 1.

Accompanying document 1 Table 1 Types

Category by conformed lamps			Classification by used places	Classification by protection for water	Classification by power factor	Classification by the maximum surface temperature of the protection function
Classification by the start method	Classification by forms	Classification symbols				
High frequency lighting dedicated type	Striplight type	FHF	For indoor	Not available	Low power factor	130°C or less 
	Compact type	FHT	For inside of instruments	Splash-proof type (SP) Watertight type (WT)	High power factor	180°C or less exceeding 130°C* 

Note * mark is the display value of the maximum surface temperature value.

4. Performance

4.1 Cathode preheating characteristics Cathode preheating characteristics must conform to the following when the test was performed according to 5.

- (1) The cathode preheating time shall be 0.4 seconds or more.
- (2) The relationship between the effective value and time of the cathode preheating current up to reaching the discharging start of the lamp shall be within the range of the minimum cathode preheating current and the maximum cathode preheating current of the current control method specified in the accompanying documents 1 attached table 1.

Remarks 1. There are two methods in the preheating control method of cathode.

- Current control preheating method
- Voltage control preheating method

In this standard, the current control method is provided.

Current control methods The required total heat in order to rise cathode to the temperature which the electron discharge becomes possible can represent by a constant determined by the physical properties of time, current and cathode.

This relation is shown in the following equation

$$te = a/(ik^2 - im^2)$$



Japanese Industrial Standard
General rules for luminaires

JIS

C8105 1987

Luminaires

1. Scope This standard specifies the basic matters about the general luminaires with AC600V or less in the rated voltage providing the light source with incandescent lamps (Halogen lamp included), fluorescent lamps, HID lamps and low pressure sodium lamps.

- Remarks**
1. These lamps must conform to the ministerial ordinance specifying the technical standard of the electric appliances.
 2. If the same item rules are available in the individual standard of luminaires, the rules are subject to the individual standard.
 3. As a principle, the meaning of for general purpose in here is excluded in the following.
 - (1) Luminaires used in places of always high temperature and low temperature in particular in ambient temperature.
 - (2) Luminaires used in places where much dust is available.
 - (3) Luminaires used in places where corrosive gas is generated.
 - (4) Luminaires used in places where flammable gas is generated.
 - (5) Luminaires used in places where strong vibration is generated.
 - (6) Luminaires used in immersed in water.
 - (7) Luminaires of vehicles and signal lights
 - (8) Luminaires for emergency according to Building Standard Law and the guide light fixtures according to Fire Service Law.
 - (9) Luminaires for take-off and landing for aircraft and airplane warning light fixtures
 - (10) Luminaires for medical care
 - (11) Luminaires made for the purposes of integrating to machines and furniture.
 - (12) Luminaires for picture shootings
 4. When the same item in JIS of parts is available, parts are able to be subject to its standard.

2. Meanings of terms Main terms meanings used in this standard are subject to the following in addition to JIS Z 8113 (Lighting terms).

- (1) **Main body (of luminaires)** This means the part fixed on the surface of building materials or the part directly hanging from building materials or the part putting on building materials and furniture. There is no objection of the presence or absence of light source, sockets and auxiliary devices (Start, lighting devices).
Remarks In the incandescent lamp lighting fixtures, the part of sockets is usually the main body.
- (2) **Ordinary type luminaires** Luminaires which are not particularly protected for dust or damp
- (3) **General luminaires** Luminaires not designed for special purposes
Remarks General luminaires mean hanging types, surface mounted type fixtures, spot light, etc., and special application luminaires such as fixtures roughly handled in building sites and factories, fixtures for picture shootings and fixtures in water are not included.
- (4) **Fixed luminaires** Luminaires fixed not so as to remove unless a tool is used, or luminaires which are used in places not easily reaching hands and which can not be easily moved from one place to the other place.
- (5) **Moving light fixtures** Luminaires which can easily move from one place to the other place as it remains connected with power supply, and luminaires fixed by easily removable device by hands connecting to power supply from plugs are included. It is also called transportable fixtures.
- (6) **Incandescent lamp (Lighting) fixtures** Luminaires using incandescent lamps as the main light source.
- (7) **Discharge lamp fixtures** Luminaires using the discharge lamp as the main light source.
- (8) **Fluorescent lamp fixtures** Luminaires using the fluorescent lamp as the main light source.
- (9) **HID luminaires** Luminaires using the HID lamp (High pressure mercury lamp, high pressure sodium lamp and metal halide lamp) as the main light source.
- (10) **Incandescent luminaires with discharge lamp in common use** Luminaires using incandescent lamps as the main light source, and incorporating the discharge lamp subsidiarily.

Quoted standard, corresponded international standard: Indicated in pages 30.

(35) **Standard ballast** This is practical ballast having the value near the central value of characteristics in lamps and ballasts when lit up the lamp.

Remarks This is used to select the light source for tests of the light source not specified in JIS.

3. Types Types of fixtures shall be as Table 1.

Table 1

Classification	Types
Used conditions	Fixed lamp, movable lamp
Installed forms or used conditions	Surface mounted type, hanging type, embedded type
Protection of electric shock	Class 0, Class I, Class II, Class III
Protection against intrusion of water	Waterproof [Dripproof (type), rainproof (type), splash proof (type), jet-proof (type), watertight (type), damp proof (type)] ordinary type
Applied light source	Incandescent lamp (Halogen lamp included), fluorescent lamp, HID lamp, low pressure sodium lamp

4. Test conditions

4.1 Test conditions Test conditions shall be ordinary temperature ($20\pm 15^{\circ}\text{C}$) specified in JIS Z 8703 (Standard conditions of test location) unless otherwise specified.

4.2 Light source for tests

- (1) When the conformed light source is the fluorescent lamp specified in JIS C 7601 [Fluorescent lamp (for general lighting)], all types fluorescent lamps displayed in the fixtures are performed in tests, using the lamp for tests specified in JIS C 8108 (Fluorescent lamp ballast).
- (2) When the conformed light source is the fluorescent lamp not specified in JIS C 7601 and it is lit up by the standard ballast, the lamp, which the lamp current and the lamp wattage are within the range of $\pm 2.5\%$ of respective rated value, is used as the lamp for tests.
- (3) When the conformed light source is the ballast built-in type fluorescent lamp, the lamp, which the lamp current and the input electric power are within the range of $\pm 2.5\%$ of respective rated value, is used as the lamp for tests.
- (4) When the conformed light source is the mercury lamp and the low pressure sodium lamp, the lamp for tests specified in JIS C 8110 (High pressure mercury lamp ballast and low pressure sodium lamp ballast) is used as the lamp for tests, and in the case of other HID lamps, when it is lit up by the standard ballast, the lamp, which the lamp current and the lamp wattage are within the range of $\pm 2.5\%$ of respective rated value, is used as the lamp for tests.
- (5) When the conformed light source is incandescent lamps and halogen lamps, the lamp of the maximum rated power consumption conforming to its fixture is used as the light source for tests.

5. Structures Structures of fixtures are subject to the following. Also, confirmation for advisability of each item is performed by visual inspection, simple and appropriate methods.

Furthermore, depending on the cases, the advisability of rules in another items is judged together.

5.1 Electrical structures The electrical structures of the fixtures must conform to the following each item.

- (1) The charging part shall not be in fear for a risk of electric shock when in used conditions and replacing the light source except for the light source and sockets.
 - (a) When the cap such as the light source contacts with the metal part (Reflector, etc) in fear for humans touching, set the mounting place (Depth) such as sockets so that enough insulation distance can keep in the space with the charging part such as lamp holders holding non-charging conditions.
 - (b) Openings part for the light source providing in the metal reflector in fear of humans touching, shall be able to be detachable in the same as (a) (...)

Figure 1

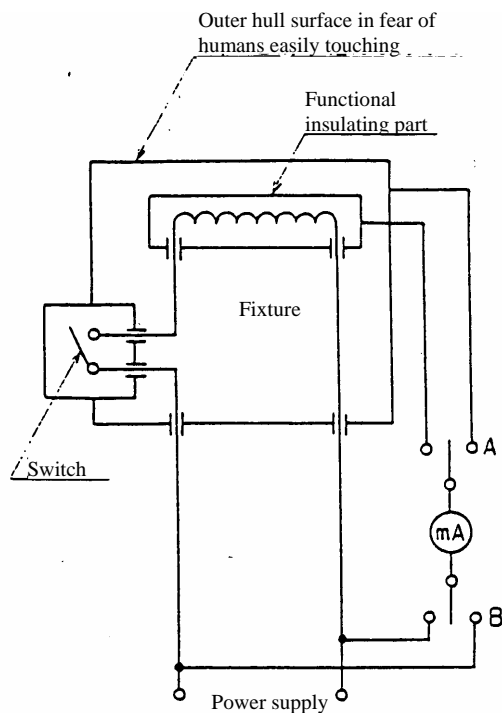

Table 11

Unit: mA

Part of fixture		Leak current
Outer hull surface in fear of humans easily touching		0.25
Fundamental insulating part	Ordinary type fixture	5
	Water proof type fixture	3.5

9.6 Input

(1) Input power of incandescent lamp fixtures, and input power and input current of fluorescent lamp fixtures must conform to Table 12 when the test was made by the method (2).

Table 12

Power consumption classification W	Electric power		Current
	Incandescent lamp fixture	Fluorescent lamp fixture	Fluorescent lamp fixture
	Allowable range of display values %		Allowable range of display values %
Fixtures using 10 or less and the circular type lamp of 30 in the classification of the lamp size	-	120 or less	±20
Less than 30	±25	120 or less	±10
30 or more/Less than 100	±20	120 or less	±10
100 or more/Less than 1000	±15	115 or less	±10
1000 or more	±10	-	-

(2) Input tests are subject to the following.

- (a) In fluorescent lamp fixtures, the lamp for tests are equipped to the fixture, and current and power on the input side are measured applying the rated voltage of the rated frequency between the input terminals at the ambient temperature of $25\pm 5^{\circ}\text{C}$.
- (b) In the case of the incandescent lamp fixture having transformers and dimmers, set the maximum conformed lamp to load, and apply the rated voltage between the input terminals, and adjust so that dimmers become the maximum load, and measure power on the input side.

10. Machine performance

10.1 Water proof performance

- (1) Water proof fixtures must have any water proof performance of Table 13 when the test was made by the method (2).

Table 13

Types of water proof protection		Performance	Applied places (Reference)
Name	Symbol		
Drip proof (type)	DP	When the test was made by the method indicating in (2) (a) Drip, there shall be no immersion which inhibits a normal operation ⁽⁵⁾ in the inside of the fixture.	In indoors, basement, under cooling ducts, underpass, etc. In house side and outdoors, places where there is almost no influence of wind such as eaves.
Rain proof (type)	RP	When the test was made by the method indicating in (2) (b) watering I, there shall be no immersion which inhibits a normal operation ⁽⁵⁾ in the inside of the fixture.	In house side and outdoors, places where are exposed to weather.
Splash proof (type)	SP	When the test was made by the method indicating (2) (c) watering II, there shall be no immersion which inhibits a normal operation ⁽⁵⁾ in the inside of the fixture.	-
Jet-proof (type)	JP	When the test was made by the method indicating (2) (d) pouring water, there shall be no immersion which inhibits a normal operation ⁽⁵⁾ in the inside of the fixture.	Tunnels of motor vehicle roads cleaning periodically, washing places of vehicles, etc.
Watertight (type)	WT	When the test was made by the method indicating (2) (e) immersion, there shall be no trace of immersion in the inside of the fixture when the test was performed by 4.9 (1) of JIS C 0920 (General rules for the water proof test of electrical machine equipment and wiring materials). When the test was made in 4.9 (2) of JIS C 0920, air shall not be leaked.	It is not only in water. Places where sometimes it has a possibility to be submerged such as pool sides.

Note ⁽⁵⁾ A normal operation means that there is no obstacles in lighting, no large changes in light properties, and there is no influence on electrical and mechanical performance.

(2) Water proof test methods are subject to the following.

Remarks Tests are performed under the condition of light-out condition unless otherwise specified.

- (a) Drip tests are subject to 4.3 or 4.4 of JIS C 0920.
- (b) In pouring water I tests, the test is subject to 4.5 of JIS C 0920 or pour water for consecutive 20 minutes (However, on the light-up condition for the first 10 minutes, and next on the light-out condition for 10 minutes) over the entire range from vertical angles to 60 degrees in the specified place as the fixtures remain mounted in normal. In this case, as a principle, the distance between the fixture and the pouring water fixture shall be 1.3m, and 10-20mm/min. in the amount of rainfall.



Fluorescent Lamp Luminaires for Commercial, Industrial and Public Lighting

C8106-1989

1. Scope This standard specifies fluorescent lamp luminaires for commercial, industrial and public lighting of AC 300V or less in the rated voltage based on the rules of JIS C 8105 (General rules for luminaires).

- Remarks**
1. Fluorescent lamps shall conform to the rules of JIS C 7601 [Fluorescent lamps (for general lighting)].
 2. The said fluorescent lamp fixtures for commercial, industrial and public lighting are as principle excluded the following.
 - (1) Fluorescent lamps subject to the remarks 3 of 1 of JIS C 8105.
 - (2) Fluorescent lamps specified to other individual standard.
 - (3) Fluorescent lamp fixtures for dimmer type facilities which dimmers are not built-in.
 - (4) Portable luminaires

2. Meanings of terms Main terms meanings used in this standard are subject to the following including the rules of JIS C 8105 and JIS Z 8113 (Lighting terms).

- (1) **Fluorescent lamp luminaires for commercial, industrial and public lighting** Fluorescent lamp fixtures which connect electric wires on the power supply side without using plugs and plating rack ceiling rosette.
- (2) **Fluorescent lamp luminaires for dimmer type commercial, industrial and public lighting** Fluorescent lamp luminaires for commercial, industrial and public lighting (Hereinafter referred to as dimmer type fixtures) which can vary luminous flux of the lamp by a built-in dimmer.
- (3) **Fluorescent lamp luminaires for lighting ducts** Fluorescent lamp luminaires having plugs to connect to the lighting duct.
- (4) **Glare of lighting fixtures** This means glare caused when the lighting fixtures with excessively high brightness exist within the range of the visual field.

Remarks Depending on the degree limiting glare of the lighting fixture, it is classified into G1, G2 and G3.

G1: Fixtures fully limiting glare by transparent covers and louvers.

G2: Fixtures which limited glare so that lamps can not see from the horizontal direction.

Quoted standard:	JIS C 1502	Ordinary noise meter
	JIS C 4908	Capacitor for electric equipment
	JIS C 7601	Fluorescent lamps (For general lighting)
	JIS C 7709	Cap and lamp holder of lamps
	JIS C 8105	General rules for lighting fixtures
	JIS C 8108	Fluorescent ballasts
	JIS C 8324	Fluorescent lamp sockets and glow starter sockets
	JIS C 8366	Lighting ducts
	JIS Z 8113	Lighting terms
	JIS Z 8731	Noise level measuring method

Corresponded international standard:

IEC 598-1	Luminaires. Part 1: Central requirements and test
IEC 598-2-1	Luminaires. Part 2: Particular requirements. Section One-Fixed general purpose luminaires
IEC 898-2-2	Luminaires. Part 2: Particular requirements. Section Two-Recessed luminaires

8. Heat characteristics

8.1 Temperature

8.1.1 Ordinary temperature Ordinary temperature is subject to the rules of 8.1.1 of JIS C 8105. Furthermore, mounting conditions of the fixtures are subject to Table 2.

Table 2

Types of fixtures	Mounting conditions
Hanging type fixtures	Fixtures are hung on the test ceiling on the ordinary used conditions or the similar conditions. At this time, the distance between the upper end of the fixture excepting hanging part of fixtures and the test ceiling shall be the standard hanging length of the manufacturers.
Surface mounted type fixtures	Fixtures are mounted on the test ceiling on the ordinary used conditions. In the case of the ceiling mounting type fixture, the test ceiling is supported horizontally, or in the case of the wall mounting type fixture, the test ceiling is supported vertically. The distance between the fixture and the wall surface shall be 0.6m or more, and the distance between the lower end of the fixture and the floor surface shall be 1m or more.
Embedded type fixtures	Fixtures are mounted on the test ceiling on the ordinary used conditions. The distance between the test ceiling & the lower end of the fixture and the floor surface shall be 1m or more. However, the fixture for which the used place is clear in advance may be mounted by the method almost commensurate with the conditions of the used place.
Wall type fixtures	As a principle, fixtures support the test ceiling vertically, and should be mounted on the severest conditions from a practical standpoint.

- Remarks**
- The test ceiling means the mounting plate of the fixture made of wood in order to keep the temperature test condition across-the-board. (Refer to the attached sheet)
 - Thickness of materials used on the test ceiling shall be 15 mm or more. However, in the test ceiling used in the embedded type fixture, the wood material to mount the fixture is okayed for 6mm or more.
 - The dimension of the test ceiling shall be larger than 100mm to each direction from the projection dimension of the fixture.

8.1.2 Abnormal temperature The abnormal temperature is subject to the following.

- When the test was made by the method of (2), it must conform to the following each item.
 - Conspicuous smoke, flame or melted insulative fillings shall not be come out to the outside.
 - Insulation resistance between non-charging metal part in fear of grounding with the charging part shall be $1M\Omega$ or more.
- In the ambient temperature of $30\pm 5^{\circ}C$ equipping the conformed lamp with the fixture, perform the process for 8 hours in (2.1) and perform the process until each part temperature saturates in (2.2) according to the following methods.
 - Apply 110% voltage of the rated voltage to between the input terminals at the rated frequency.
 - Apply the rated voltage of the rated frequency to between the input terminals, and perform the test under the severest conditions in temperature from the following conditions.

Furthermore, in the case of the multiple light fixture, after lighting up all lamps normally, the test is performed about 1 piece which is the severest condition.

 - Short circuit of the starter
 - Remove the lamp.
 - The lamp which both electrodes are energized, but not started.
 - Open one electrode of the lamp.
 - Short circuits of power factor improved capacitor not connected in parallel with power supply (When the input voltage was varied to 90-110% or less of the rated voltage in the ordinary used condition, the capacitors whose terminal voltage falls in the rated voltage or less of the capacitor are excluded.)

8.2 Heat deformation Heat deformation is subject to the rules of 8.2 of JIS C 8105.

8.3 Heat resistance Heat resistance is subject to the rules of 8.3 of JIS C 8105.

8.4 Fire resistance Fire resistance is subject to the rules of 8.4 of JIS C 8105.

9. Electrical characteristics

9.1 Light-up Light-up is subject to the rules of 9.1 of JIS C 8105. However, in the case of the dimmer type fixtures, the light-up test is performed about the maximum condition in the lamp wattage and the minimum lamp wattage condition to which manufacturers guarantee.

9.2 Starting When the test was made by the method specified in the rules of 9.2 (2) of JIS C 8105, the starting must conform to the rules of Table 3. However, in the case of the dimmer type fixture, the test is performed under the condition of the lamp wattage becoming the maximum.

Table 3

Classification by the start method	Glow starter method	Manual starter method	Electronic starter method	Electronic ballast	Rapid start method with the size classification of the conformed lamp being 40 or less	Rapid start method with the size classification of the conformed lamp exceeding
Start time	7 sec. or less	More than one time light-up out of 3 cycles	4 sec. or less	3 sec. or less	3 sec. or less	5 sec. or less

9.3 Insulation resistance Insulation resistance is subject to the rules of 9.3 of JIS C 8105.

9.4 Withstand voltage The withstand voltage is subject to the rules of 9.4 of JIS C 8105.

9.5 Leak current Leak current is subject to the rules of 9.5 of JIS C 8105.

9.6 Input Input is subject to the rules of 9.6 of JIS C 8105.

9.7 Power factor In the case of high power factor type fixture, power factor must be 0.85 or more in the power factor calculated from the current value and the power value in the input test.

9.8 Noises The lamp for tests is equipped to the fixture, and the rated voltage of the rated frequency is applied to between input terminals, and after the light-up condition stabilized, and then when noises generated from the fixture were measured according to the rules of JIS Z 8731 (Noise level measuring method) with using the sound-level meter (A characteristics in frequency corrective circuits) specified in JIS C 1502 (Ordinal noise meter) or according to the rules of JIS Z 8731 (Noise level measuring method) using the equivalents or more level, the noises must be the degree of no obstruction on a practical basis.

10. Mechanical performance

10.1 Water proof performance Water proof performance is subject to the rules of 10.1 of JIS C 8105.

10.2 Damp proof performance Damp proof performance is subject to the rules of 10.2 of JIS C 8105.

10.3 Heat resistance impacts Heat resistance impacts are subject to the rules of 10.3 of JIS C 8105.

10.4 Impact resistance Impact resistance is subject to the rules of 10.4 of JIS C 8105.

11. Light characteristics (Glare) It is desired that brightness in each vertical angle due to the glare limit is the value of Table 4 or less in the fixture using the straight pipe type 40 fluorescent lamp.



Japanese Industrial Standard
Ballasts for fluorescent lamps

JIS

C8108-1991

1. Scope This standard specifies the ballast used in general places with the rated input voltage being 300V or less of AC (50 Hz only, 60 Hz only and 50 Hz/60 Hz in common use) and with 1000 V or less in the rated secondary voltage out of the magnetic circuit type ballast (Hereinafter referred to as a ballast) used in the lighting of the fluorescent lamp and the low pressure mercury lamp (Hereinafter referred to as a lamp) specified in JIS C 7601 and JIS C 7605.

- Remarks**
1. The following indicates the quoted standard in this standard.
 - JIS C 0920 Water proof test general rules for electrical machinery & apparatus and wiring materials
 - JIS C 1102 Electrical indicating meter
 - JIS C 1302 Insulation-resistance tester (battery-operated)
 - JIS C 1502 Ordinary noise meter
 - JIS C 1505 Precision sound level meter
 - JIS C 1602 Thermocouple
 - JIS C 2353 Coil impregnated varnish for electrical insulation
 - JIS C 3301 Rubber cord
 - JIS C 3306 Vinyl cord
 - JIS C 3307 600 V vinyl insulated wire (IV)
 - JIS C 3309 1000 V fluorescent discharge lamp wire
 - JIS C 3315 Rubber insulated wire for lead wire
 - JIS C 3316 Vinyl insulated wire for electrical machinery & apparatus
 - JIS C 4003 Types of electrical machinery & apparatus insulation
 - JIS C 4908 Capacitor for electrical machinery & apparatus
 - JIS C 7601 Fluorescent lamp (For general lighting)
 - JIS C 7605 Low pressure mercury discharge tube for sterilization
 - JIS Z 8113 Lighting terms
 2. The following indicates the corresponded international standard of this standard.

2. Definition of terms The main terms definition used in this standard is subject to the following including JIS Z 8113.

- (1) **Magnetic circuit type ballasts** The magnetic circuit type ballast constitutes transformers and choke coils as a main component, if necessary, in combination with capacitors and is a ballast used in order to appropriately operate the lamp. The ballast may include capacitors for noise elimination, capacitors for power factor improvements, capacitor discharge resistance, protective device and semiconductor device for starting.
- (2) **Ballasts for tests** This is a choke coil type ballast used as a standard in order to select the test of ballasts and test lamps. (Refer to accompanying documents 1)
- (3) **Lamps for tests** This is a lamp with less characteristics variation lighting up for a long time in advance in order to test the ballast and fully killing it to use as a load (Refer to accompanying document 2).

Accompanying documents 2 Lamps for tests

Lamps for tests are measured at $25\pm 1^\circ\text{C}$ under fully stabilized conditions using the ballast for tests and the instrument specified in the main body 6.1.4 while applying the rated input voltage of the rated frequency specified in the main body 6.1.2 and lighting it by the method specified in 8.3.5 (Initial characteristics test) of JIS C 7601. The lamps indicated in the accompanying documents 2 Table 1 and the accompanying documents 2 Table 2 must conform to the respective table, and the others must fall in within $\pm 2.5\%$ of the rated value of the relevant lamp.

Accompanying documents 2 Table 1 Lamp characteristics for tests

Types of lamps for tests	Lamp wattage W	Lamp voltage (Standard value) V	Lamp current A
FL4	4.6 ± 0.5	30	0.162 ± 0.006
FL6	5.9 ± 0.5	44	0.147 ± 0.006
FL8	7.9 ± 0.5	56	0.170 ± 0.006
FL10, GL10	9.5 ± 1.0	46	0.23 ± 0.01
FL15, FL15	14.7 ± 1.0	55	0.30 ± 0.01
FL20S	19 ± 1	58	0.36 ± 0.01
FL20SS/18	18 ± 1	59	0.34 ± 0.01
FCL20	19 ± 1	58	0.375 ± 0.010
FCL20/18	18 ± 1		0.365 ± 0.010
FL30S	30 ± 1	55	0.610 ± 0.015
FCL30	29 ± 1		
FCL30/28	28 ± 1		
FCL32	31.5 ± 1.0	83	0.435 ± 0.010
FCL32/30	30 ± 1		0.425 ± 0.010
FL40S	39.5 ± 1.0	106	0.42 ± 0.01
FL40S/38	38 ± 1	109	0.41 ± 0.01
FL40SS/37	37 ± 1	108	
FCL40	39.5 ± 1.0	103	0.435 ± 0.010
FCL40/38	38 ± 1		0.425 ± 0.010
FLR20S	19 ± 1	58	0.36 ± 0.01
FLR40S	39.5 ± 1	106	0.42 ± 0.01
FLR40S/36	36 ± 1	96	0.44 ± 0.01
FLR110H	109 ± 3	159	0.80 ± 0.02
FLR110H/100	100 ± 3	142	

Accompanying documents 2 Table 2 Lamp characteristics for tests

Types of lamps for tests	Lamp wattage W	Lamp voltage (Standard value) V	Lamp current A
FPL4	4.0±0.5	33	0.162±0.007
FPL6	6.0±0.5	40	0.147±0.007
FPL9, FWL9	9.0±1.0	44	0.23±0.01
FDL9, FML9	9.3±1.0	53	
FGL9	8.8±1.0	58	0.20±0.01
FPL13, FWL13	13.0±1.0	54	0.30±0.01
FDL13, FGL13, FTL13	13.3±1.0		
FML13	13.5±1.0	52	
FPL18, FWL18	18.0±1.0	57	0.375±0.010
FDL18, FML18	17.5±1.0	55	
FPL27, FWL27	27.0±1.0	54	0.610±0.015
FDL27, FML27	26.8±1.0	56	
FPL30	29.0±1.0	55	0.620±0.015
FPL28	28.4±1.0	80	0.425±0.010
FPL36	36.0±1.0	102	0.435±0.010
FML36, FWL36	36.0±1.0	105	
FPL55	55.0±1.5	109	0.670±0.015
FPX5 ⁽¹⁾	5.4±0.5	35	0.170±0.006
FPX5 ⁽²⁾	55.5±0.5		0.180±0.006
FPX7 ⁽¹⁾	6.9±0.5	45	0.170±0.006
FPX7 ⁽²⁾	7.0±0.5		0.180±0.006
FPX9 ⁽¹⁾	8.7±0.5	60	0.170±0.006
FPX9 ⁽³⁾	9.0±0.5		0.180±0.006
FPX11	11.4±0.5	90	0.155±0.006
FPX13	13.4±1.0	59	0.285±0.010
FDX10	10.0±1.0	67	0.19±0.01
FDX13	13.0±1.0	100	0.165±0.010
FDX18	18.0±1.0	105	0.22±0.01
FDX26	26.0±1.0	110	0.315±0.010

Note ⁽¹⁾ Characteristics value when the reference voltage of the ballast for tests is 220 V

⁽²⁾ Characteristics value when the reference voltage of the ballast for tests is 100 V

⁽³⁾ Characteristics value when the reference voltage of the ballast for tests is 118 V



1. Scope This standard specifies a table study lamp for fluorescent lamps (Hereinafter referred to as a stand) in consideration for providing necessary light in order to improve the view operation efficiency for use such as study, reading, etc. with 100 V in the rated voltage (Secondary voltage included) using the fluorescent lamp specified in JIS C 7601 [Fluorescent lamps (for general lighting)].

2. Meanings of terms Meanings of the main terms used in this standard are subject to the following including JIS Z 8113 (Lighting terms) and JIS C 8106 (Fluorescent fixtures).

- (1) **Portable type (Table study lamps for fluorescent lamps)** Table study lamps for fluorescent lamps which can move on the desk as power supply remains connected.
- (2) **Installed type (Table study lamps for fluorescent lamps)** Table study lamps for fluorescent lamps manufactured so that it can easily mount on furniture or building materials with the fixture.
- (3) **High illumination type (Table study lamps for fluorescent lamps)** Table study lamps for fluorescent lamps having the light-up circuit which was arranged to increase the lamp wattage and luminous flux enhancing the current value carrying to the tube lighting circuit more than the standard value of the conformed lamps.
- (4) **Normal posture** Used postures of the stand which manufactures clearly demonstrated to users by the instruction manual in order to guarantee the stand performance.

3. Types Types of the stand are subject to the combination of the classification of Table 1.

Table 1

Classification by illumination on the desk	Classification by lamp wattage	Classification by forms
Type AA	Ordinary type	Portable type
Type A	High illumination type	Installed type
General type ⁽¹⁾		

Note ⁽¹⁾ There are no rules of illumination on the desk for the general type.

4. Performance

4.1 Light-up Light-up is subject to 4.1 of JIS C 8106.

4.2 Starting Starting is subject to 4.2 of JIS C 8106.

Quoted standards: JIS C 1502 Ordinary noise meter
 JIS C 1609 Illuminance meter
 JIS C 7601 Fluorescent lamps (for general lighting)
 JIS C 8106 Fluorescent lamp fixtures
 JIS C 8108 Fluorescent lamp ballasts
 JIS Z 8113 Illumination terms
 JIS Z 8731 Noise level measuring methods

Corresponded international standards :

IEC 598-2-4 Luminaires Part 2: Particular requirements Section Four: Portable general purpose luminaires

6.3.10 Illumination Illumination is measured on 1/3 circumference of the front 50 cm radius and on 1/3 circumference of 30 cm radius of the stand centering the point immediately under the lamp center as indicated in Fig.2, using the stand having corrected illumination on the desk surface in angle with an illuminance meter of Class A specified in JIS C 1609 (Illuminance meter) or the equivalents or more level placing the stand on the condition of 6.3.9.

Furthermore, the ambient temperature of the stand and the photoreceptor of the illuminance meter shall be, in principle, almost Draught free environment setting the temperature at $20\pm 5^{\circ}\text{C}$.

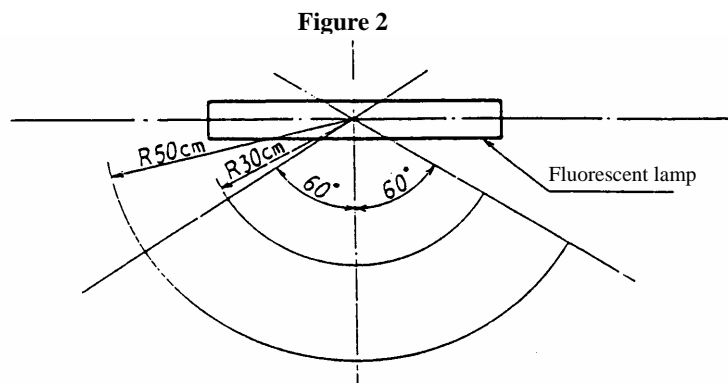

6.3.11 Input Input is subject to 6.5.11 of JIS C 8106.

6.3.12 Insulation resistance Insulation resistance is subject to 6.5.8 of JIS C 8106.

6.3.13 Withstand voltage Withstand voltage is subject to 6.5.9 of JIS C 8106.

6.3.14 Noises In noises, the lamp for tests is equipped to the stand specified in JIS C 8108 (Fluorescent lamp ballasts), the rated voltage of the rated frequency between the input terminals is applied and the lamp is lit up, and place the stand on the wood plate of 15-25 mm in thickness by the method specified in JIS Z 8731 (Noise level measuring method) using a noise meter with the frequency corrective circuit A characteristics of the sound level meter specified in JIS C 1502 (Ordinary noise meter) or the equivalents or more level, and measure the noise generated in the point of 10 cm on the front 45° oblique line on the center axis of the base of the stand (Refer to fig.3). However, in the case of the stand having the ballast in the vicinity of the shade, measure in the point of 10 cm of the horizontal distance apart from the center of the frontward lower end of the shade (Refer to Fig. 4).

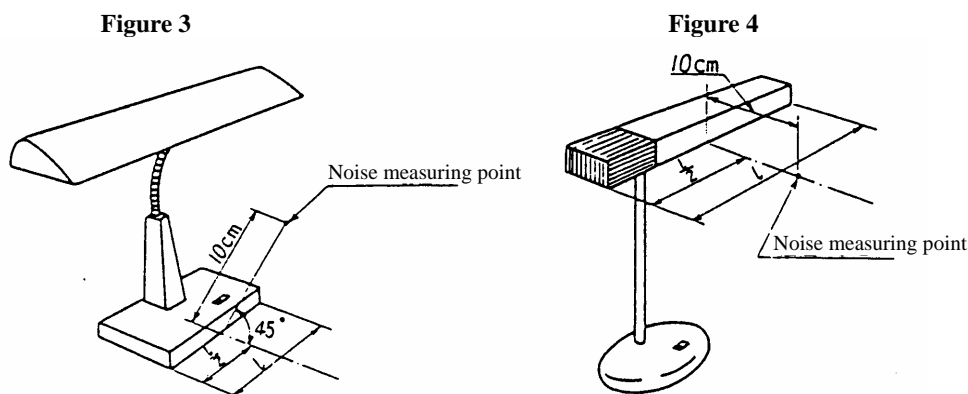

6.3.15 Mounting strength of wire connecting to power supply In the mounting strength of wires connecting to power supply, apply tension (When 3-fold values of the weight of the fixture exceed 10 kg, the value is 100N, and when 3-fold values of the weight of the fixture are less than 3 kg, the value is 30N) equivalent to 3-fold values of the weight of the fixture toward the outside direction of the fixture on the wire connecting to power supply for 15 seconds, and push in the wire connecting to power supply toward the inside of the fixture holding the place of 5 cm apart from the fixture itself, and make a test.

6.3.16 Bend of wires connecting to power supply Bends of wires connecting to power supply make the through-part of the fixture body agree to the center of movable plate of the test device as indicated in Fig.5, and the wire connecting to power supply or the wire for connections will not bend at the center of the movable range, and mount the fixture body on the movable plate so as to become the vertical angle, (...)



1. Scope This standard specifies the fluorescent lamp luminaires for residential lighting of 100 V in the rated voltage based on the rules of JIS C 8105 (General rules for lighting fixtures).

- Remarks**
1. Fluorescent lamps shall conform to the rules of JIS C 7801 [Fluorescent lamp (For general lighting)].
 2. The said fluorescent lamp luminaires for residential lighting are, in principle, excluded in the following luminaires.
 - (1) Luminaires subject to the remarks 3 of 1 of JIS C 8105.
 - (2) Water proof luminaires
 - (3) Movable lamps (Portable type) such as stands, floor stands, etc.
 - (4) Luminaires specified in other individual standards

2. Meanings of terms The meanings of the main terms used in this standard are subject to the following including JIS C 8105 and JIS Z 8113 (Lighting terms).

- (1) **Fluorescent lamp luminaires for residential lighting** Fluorescent lamp luminaires for residential lighting which can easily connect with the power supply with plugs and plating rack ceiling rosette as a principle and the lighting fixtures which are mainly used in houses using the fluorescent lamp as the main light source.
- (2) **Dimmer type fluorescent lamp luminaires for residential lighting** Fluorescent lamp luminaires for residential lighting (Hereinafter referred to as a dimmer fixture) which can change luminous flux of the lamp with the built-in dimmer.

3. Types Types of the luminaires are subject to Table 1.

Table 1

Classification	Types
Mounted forms	Hanging type, surface mounted type, wall-hung type
Protection of electric shock	Class 0, class I, class II

4. Test conditions Test conditions are subject to the rules of 4.1 and 4.2 (1), (2) of JIS C 8105

Quoted standards:	JIS C 1502 Ordinary noise meter JIS C 4908 Capacitor for electrical machinery & apparatus JIS C 7601 Fluorescent lamp (For general lighting) JIS C 7709 Cap and lamp holder of lamps JIS C 8105 General rules for lighting fixtures JIS C 8108 Ballasts for fluorescent lamps JIS C 8303 Plug connector for wiring JIS C 8310 Ceiling rosette JIS C 8324 Fluorescent lamp sockets and glow starter sockets JIS Z 8113 Lighting terms JIS Z 8731 Noise level measuring methods
Corresponded international standards:	IEC 598-1 Luminaires. Part 1: General requirements and tests IEC 598-2-1 Part 2: Particular requirements. Section One-Fixed general purpose luminaires

5. Structures The structures of the fixture are subject to the rules of 5 of JIS C 8105, and the strength of the switch pulling strings are subject to the following.

- (1) In the hanging type fixture, after mounting the fixture on the normal position, the strength shall withstand when applied tensile load of 50N to the tip of the pulling string for 1 minute.
- (2) Then, when applied gradually the tensile load to the tip of the pulling string until reaching 150N, the pulling string shall be cut or come off. At this time, the handle of the switch shall withstand the tensile load when the pulling string was cut or come off.

6. Materials Materials are subject to the rules of 6 of JIS C 8105.

7. Parts

7.1 Ballasts The ballast used in the fixture is subject to the following in addition to the ballast which its rated voltage equals to that of the fixture.

- (1) The ballast of the fixture for 100 V of the rated voltage used in the fluorescent lamp specified in JIS C 7601 (Accompanying documents 1 and accompanying documents 2 are excepted) shall conform to the rules of JIS C 8108 (Ballasts for fluorescent lamps).
- (2) The ballast of the fixture using the fluorescent lamp specified in the accompanying document 1 or the accompanying document 2 of JIS C 7601 shall have the start characteristics agreed with the lamp characteristics and the output performance pursuant to the rules of 4.5 of JIS C 8108, and shall have the required electrical characteristics, heat characteristics and mechanical performance.
- (3) The electronic ballast of the fixture using the fluorescent lamp specified in JIS C 7601 shall have the start characteristics agreed with the lamp characteristics and the output performance pursuant to the rules of 4.5 of JIS C 8108, and shall have the required electrical characteristics, heat characteristics and mechanical performance.
- (4) The ballast used in the dimmer type fixture shall be pursuant to the rules of the respective relevant (1), (2) or (3) on the condition of the lamp wattage becoming the maximum.

7.2 Sockets Fluorescent lamp sockets and glow starter sockets are subject to either of the following.

- (1) The fluorescent lamp socket used in the fluorescent lamp specified in JIS C 7601 (Accompanying document 1 and accompanying document 2 are excluded) shall conform to the rules of JIS C 8324 (Fluorescent lamp sockets and glow starter sockets).
- (2) The fluorescent lamp socket used in the fluorescent lamp specified in the accompanying documents 1 and accompanying documents 2 of JIS C 7601 shall be subject to the rules of the accompanying documents of this standard.

Furthermore, when incorporating the socket with not having the prevention structure for misuses, the socket shall have the structure to prevent the lamp other than conformed lamps from using.

- (3) The glow starter socket shall conform to the rules of JIS C 8324.
- (4) Incorporated structure (such as the fluorescent lamp socket and the glow starter socket become integrated) shall be pursuant to the rules of respective relevant (1), (2) and (3).

7.3 Capacitors Capacitors (Small sized ones such as for prevention of noises are excluded) must be the ones specified in JIS C 4908 (Capacitors for electrical machinery & apparatus) or the equivalents or more level.

Furthermore, it is desired that they are the capacitors with safety mechanism specified in JIS C 4908 or the capacitors built-in safety devices.

7.4 Plugs Plugs must conform to the rules of JIS C 8303 (Plug connector for wiring).

7.5 Plating rack ceiling rosette Plating rack ceiling rosettes must conform to the rules of JIS C 8310 (Ceiling rosettes).

8. Heat characteristics

8.1 Temperature

8.1.1 Ordinary temperature When the test was made according to the rules of 8.1.1 (2) of JIS C 8105 after mounting the fixture on the condition indicated in Table 2, the temperature must conform to 8.1.1 (1) of JIS C 8105. However, the surface temperature of the hanging type fixture must conform to Table 3.

Table 2

Types of fixtures	Mounting conditions
Hanging type fixtures	Fixtures are, as a principle, hung on the test ceiling on the ordinary used conditions or the similar conditions. At this time, the distance between the upper end of the fixture excepting hanging part of fixtures and the test ceiling shall be the standard hanging length of the manufacturers.
Surface mounted type fixtures	Fixtures are mounted on the test ceiling on the ordinary used conditions. In the case of the ceiling mounting type fixture, the test ceiling is supported horizontally, or in the case of the wall mounting type fixture, the test ceiling is supported vertically. The distance between the fixture and the wall surface shall be 0.6m or more, and the distance between the lower end of the fixture and the floor surface shall be 1m or more.
Wall type fixtures	As a principle, fixtures support the test ceiling vertically, and should be mounted on the severest conditions from a practical standpoint.

- Remarks**
1. The test ceiling means the mounting plate of the fixture made of wood in order to keep the temperature test condition across-the-board. (Refer to the attached figure 1)
 2. Thickness of materials used on the test ceiling shall be 15 mm or more.
 3. The dimension of the test ceiling shall be larger than 100mm to each direction from the projection dimension of the fixture.

Table 3

Part of fixtures		Unit: °C
		Temperature limit
Outer shell such as main body, reflector and shade		75 ⁽¹⁾
Handles which humans operate during using, or knobs and push buttons such as flashing devices	Metal, ceramics, glass	48
Handles which humans operate during using, or knobs and push buttons such as flashing devices	Others	60

Note ⁽¹⁾ In the outer shell of the fixture, the upper part where humans are little fear of easily touching may be okayed at 80°C or less in the temperature limit.

Remarks The reference ambient temperature shall be 30°C.

8.12 Abnormal temperature

The abnormal temperature is subject to the following.

- (1) When the test was made by the method of (2), it must conform to the following each item.
 - (a) Conspicuous smoke, flame or melted insulative fillings shall not be come out to the outside.
 - (b) Insulation resistance between non-charging metal parts in fear of grounding with the charging part shall be 1MΩ or more.
- (2) In the ambient temperature of 30±5°C equipping the conformed lamp with the fixture, perform the process for 8 hours in (2.1) and perform the process until each part temperature saturates in (2.2) according to the following methods.
 - (2.1) Apply 110% voltage of the rated voltage to between the input terminals at the rated frequency.
 - (2.2) Apply the rated voltage of the rated frequency to between the input terminals, and perform the test under the severest conditions in temperature from the following conditions.

Furthermore, in the case of the multiple light fixture, after lighting up all lamps normally, the test is performed about 1 piece which is the severest condition.

 - (a) Short circuit of the starter
 - (b) Remove the lamp.
 - (c) The lamp which both electrodes are energized, but not started.
 - (d) Open one electrode of the lamp.
 - (e) Short circuits of power factor improved capacitor not connected in parallel with power supply (When the input voltage was varied to 90-110% or less of the rated voltage in the ordinary used condition, the capacitors whose terminal voltage falls in the rated voltage or less of the capacitor are excluded.)

8.2 Heat deformation

Heat deformation is subject to the rules of 8.2 of JIS C 8105.

8.3 Heat resistance

Heat resistance is subject to the rules of 8.3 of JIS C 8105.



1. Scope This standard specifies the electronic ballast used in general places with the rated input voltage being 300V or less of 50 Hz, 60 Hz and 50 Hz/60 Hz in common use and with 1000 V or less in the rated secondary voltage out of the AC supplied electronic ballast for indoors or for the inside of the fixture used in the lighting of the fluorescent lamp specified in JIS C 7601 (However, accompanying document 2 excluded) and the low pressure mercury lamp (Hereinafter referred to as a lamp) specified in JIS C 7605. However, electronic ballasts with the structure without having the outer shell and with integrated with the fixture are excluded.

Remarks 1. The following indicates the quoted standard in this standard.

- JIS C 0025 Environmental test methods (Electricity/electronic) temperature change test methods
 - JIS C 0920 Water proof test general rules for electrical machinery & apparatus and wiring materials
 - JIS C 1102 Electrical indicating meter
 - JIS C 1302 Insulation-resistance tester (Battery type)
 - JIS C 1502 Ordinary noise meter
 - JIS C 1505 Precision sound level meter
 - JIS C 1602 Thermocouple
 - JIS C 2353 Coil impregnated varnish for electrical insulation
 - JIS C 3301 Rubber cord
 - JIS C 3306 Vinyl cord
 - JIS C 3307 600 V vinyl insulated wires (IV)
 - JIS C 3309 1000 V fluorescent discharge lamp wires
 - JIS C 3315 Rubber insulated wires for lead wires
 - JIS C 3316 Vinyl insulated wires for electrical machinery & apparatus (KIV)
 - JIS C 4908 Capacitor for electrical machinery & apparatus
 - JIS C 6481 Test methods for copper-clad laminates for printed wiring boards
 - JIS C 7601 Fluorescent lamp (For general lighting)
 - JIS C 7605 Low pressure mercury discharge tube for sterilization
 - JIS C 8108 Ballasts for fluorescent lamps
 - JIS Z 8113 Lighting terms
2. The following indicates the corresponded international standard in this standard.
- IEC 928 (1990) A.C. supplied electronic ballasts for tubular fluorescent lamps
General and safety requirements
 - IEC 929 (1990) A.C. supplied electronic ballasts for tubular fluorescent lamps –
Performance requirements

2. Definition of terms The main terms definition used in this standard is subject to the following including JIS Z 8113.

- (1) **AC supplied electronic (Circuit type) ballasts for fluorescent lamps** The electronic ballast has the start and light-up circuits in combination with the entire part or a part such as semiconductor device and transformers, choke coils and capacitors, and these constitute in integrated or separated part, and have a function to properly light up the lamp converting AC-AC (In general, mains frequency- high frequency) by semiconductor devices in both starting the lamp and during lighting up (...)

- (2) **Ballasts using the rapid start type lamps** When applying the rated input voltage of the rated frequency between the input terminals, connecting artificial load resistance indicated in Table 3 to cathode preheating winding in the ballast, for example, as indicated in Fig.5, measure the both ends voltage of the artificial load resistance.

Remarks In the ballast which preheating current or preheating voltage change as time passes, the average effective value current in its time or the time average of the effective value may be determined by the calculation, observing the preheating current or the preheating voltage waveform from in starting preheating to the period over 0.4 seconds by the cathode ray oscilloscope.

Fig.5 Ballasts using the rapid start type lamp

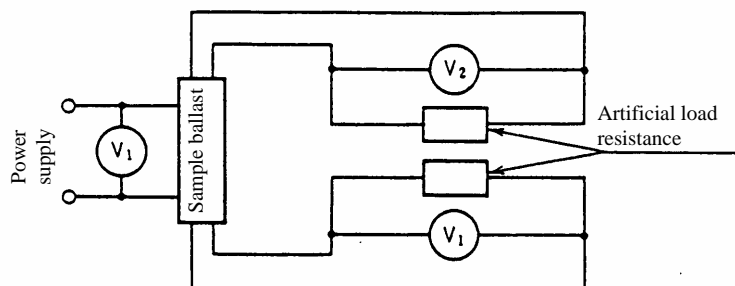

6.2.5 Secondary short circuit current tests Apply the rated input voltage of the rated frequency between the input terminals of the ballast, and short terminal to terminal specified in 6.2.2 by the ammeter, then measure it.

Remarks In the ballast which the secondary current in shorting changes intermittently, the maximum indicated value of the effective value indicating instrument is regarded as the secondary short circuit current.

Furthermore, the average of the effective value may be determined by the calculation observing the waveform with the cathode ray oscilloscope.

6.2.6 Lamp current and light output tests In the lamp current and the light output test, connect the ballast, for example, as indicated in Fig.6, and the lamp current applies the rated input voltage of the rated frequency to the sample ballast and measure it, and determine the ratio against the rated secondary current value displayed in the ballast. In the light output, determine the ratio when applying the rated input voltage of the rated frequency to the sample ballast and when applying the reference voltage for tests of the rated frequency to the ballast for tests. The test may be okayed connecting as indicated in (a) or (b) of Fig.7 in either the case where the changes of the measured value of the sample ballast can be negligible or where its correction becomes possible.

- Remarks**
1. In the measurement of the light output, measure using the illumination meter fixed in a certain distance from the center part of the lamp. In this case, shield light receiving part from light other than the lamp.
 2. The ballast which the intermediate conductor is provided to measure the lamp current from the ballast is measured connecting the ammeter to its both ends.
 3. When the rapid start type lamp is lit up by the ballast for tests, the cathode preheating transformer is used, but this secondary voltage is connected so that voltage of the main circuit is not increased, and its rated secondary voltage shall be 3.6V.

Fig.6 Lamp current and light output measuring circuits

(a) Ballasts using the starter type lamp

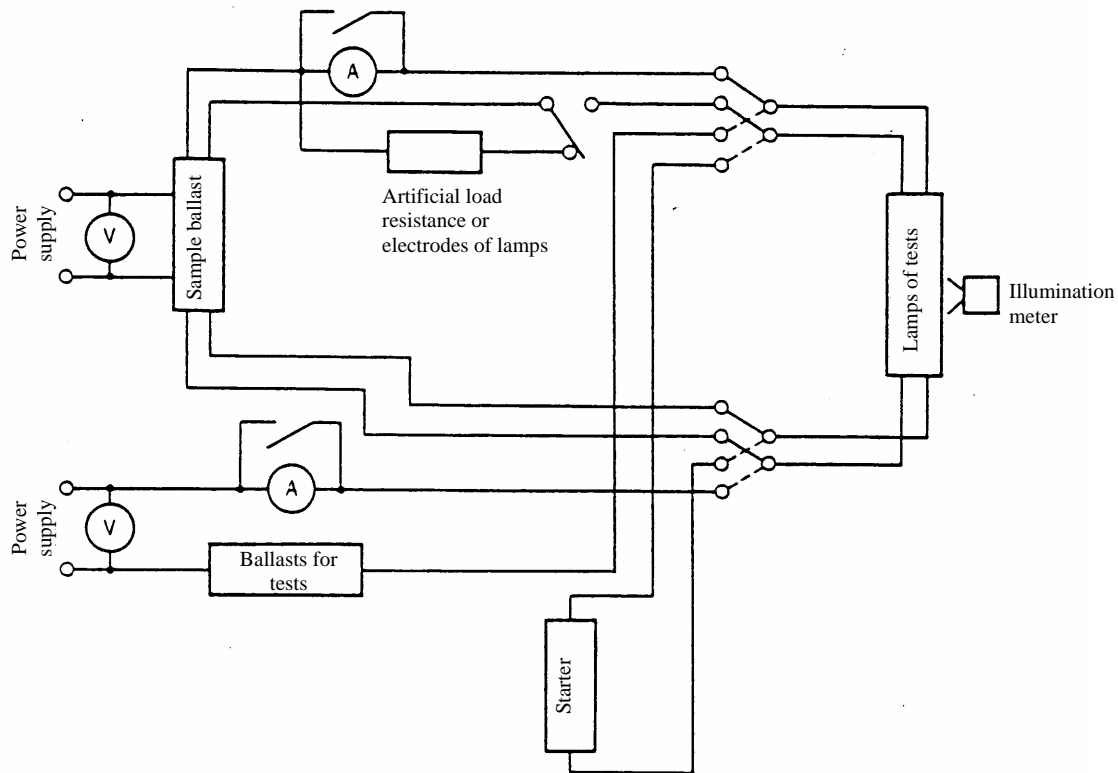

(b) Ballasts using the rapid start type lamp

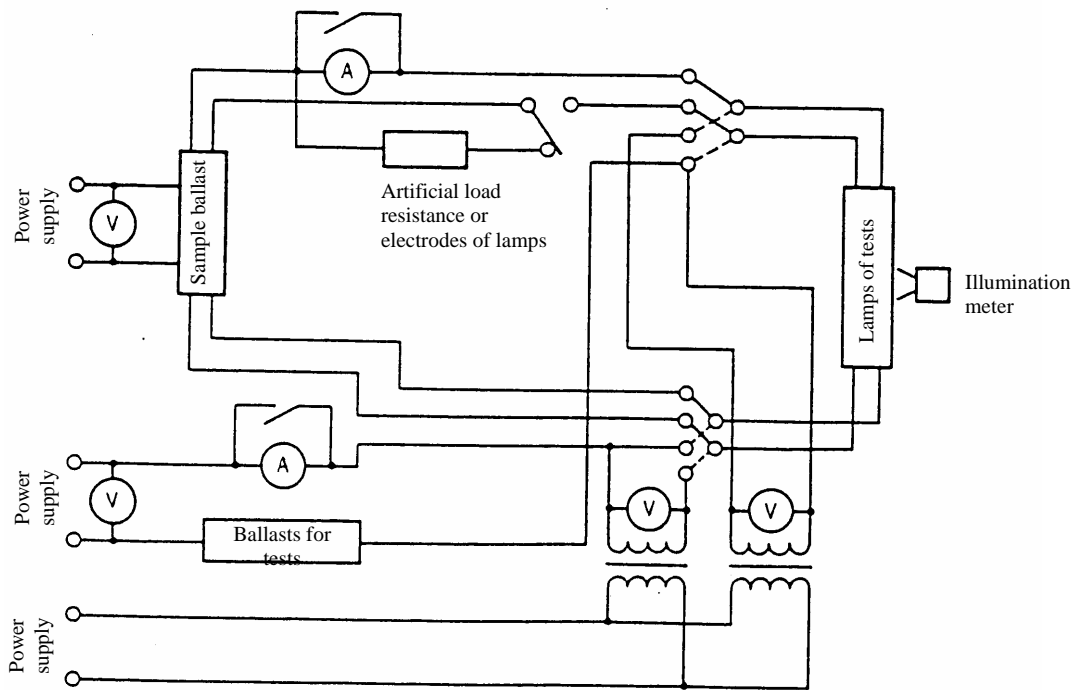



1. Scope This standard specifies about the following electrical indicating instruments (Hereinafter referred to as instruments) for the next DC and AC.

- (1) Voltmeter, ammeter, voltammeter, wattmeter, reactive-power meter, phase meter, power-factor meter, reactive-factor meter and frequency meter.

Remarks In the voltammeter, the rules of the voltmeter and the ammeter are applied.

- (2) Out of the instrument indicated in (1), instruments having accessory fixtures (Multiplier, shunt, transformer for instruments, AC transducer)

(a) The instrument having the dedicated accessory instrument and the semi-private accessory instrument is applied on the combined condition.

(b) In the instrument having the general accessory fixtures, the instrument main body is applied in this standard, and the general accessory fixtures are applied to the relevant standard.

- (3) Receiving indicator In the receiving indicator, the scale is converted to voltage or current, and this standard is applied regarding as the voltmeter or the ammeter.

Remarks The indicator specified in other Japanese Industrial Standard is not applied.

However, the instrument (Accessory instruments are included) requiring power supply from the outside (Other than the circuit under test) or built-in batteries and meter relay, utility meter, record meter and integrating meter are excluded.

2. Meanings of terms The meanings of the main terms used in this standard are as follows.

- (1) Electrical indicating meter

(a) **Electrical indicating meter** The instrument indicating the value of the measuring volume related to electricity.

The value of the measuring volume is instructed by the pointer against the scale plate.

(b) **Measuring element** The measuring element consists of fixed elements and movable elements, and the drive torque related to the value of measuring volume is generated, and is a part instructing the measured value to the movable element.

(c) **Voltage circuit** Circuit part between the instrument terminals which voltage of the circuit trying measurement is applied directly or indirectly.

(d) **Current circuit** Circuit part between the instrument terminals which current of the circuit trying measurement is carried directly or indirectly.

(e) **Multiplier** Resistor connecting in series with the instrument terminal to expand the voltage range of the instrument.

(f) **Shunt** Resistor connecting in parallel between the instrument terminals to expand the current range of the instrument.

(g) **Transformer for instruments** This is the transformer for instruments of current and voltage using the instrument together, and is a generic name of the transformer, the transformer for instruments and the combined voltage current transformer.

(h) **AC transducer** Instruments converting the electricity volume of AC to that of DC in the transducer instrument.

Quoted standard:	JIS C 0911 Vibration test method of small-sized electrical machinery & apparatus JIS C 0912 Impact test method of small-sized electrical machinery & apparatus JIS C 1103 Dimension for the electrical indicating meter for the switchboard JIS C 1105 Dimension of the edgewise electrical indicating meter JIS C 1301 Insulation resistor (Generator method) JIS C 1302 Insulation resistor (Battery method) JIS C 1721 Shunt JIS C 1731 Transformer for instruments (For standard and for general instruments) JIS G 3101 Rolled steel for general structures JIS Z 8202 Volume symbol, unit symbol and chemical symbol
Related standards:	JIS C 1002 Terms for electronic measuring apparatus JIS Z 8103 Measurement terms

- (7) **Allowable difference** Limit values of percentage error allowable in the standard test condition.
- (8) **Influence volume** Volume influencing on the indicating value other than the volume for the purpose of measurement.
- (9) **Influence** Indication changes generated in the instrument when one influence volume was varied from the reference value.
- (10) **Allowable limit** Limit value of influence allowable to the instrument and the accessory fixture.
- (11) **Class** Class which the instrument and the accessory fixture are classified by its allowance difference and the allowable limit.
- (12) **Response**
- (a) **Response time** When the input abruptly changed from a certain value to the other certain value, time until the pointer falls under the specific range of the final value.
- (b) **Too much swing** When the input abruptly changed from a certain value to the other certain value, if the pointer exceeds the final value transiently, the maximum volume of swing from the final value.
- (13) **Applications**
- (a) **For setting down** Instruments used setting down at its used place such as the test base usually with the general outer shape and mass being large and having the level.
- (b) **For portable** Instruments of structures convenient for portable with the general outer shape and mass being small comparing to the instrument for setting down.
- (c) **For switchboard** Instruments used mounting switchboards and panels

3. Types

3.1 Types by measuring volume Types are classified into the voltmeter, ammeter, voltammeter, wattmeter, reactive-power meter, phase meter, power-factor meter, reactive-factor meter, frequency meter and receiving indicating meter by measuring volume.

3.2 Type of class

- (1) The voltmeter, ammeter, voltammeter, wattmeter and reactive-power meter shall be five classes in Class 0.2, Class 0.5, Class 1.0, Class 1.5 and Class 2.5.
- (2) The phase meter, power-factor and reactive-power meter shall be two classes in Class 3.0 and Class 5.0.
- (3) The frequency meter shall be three class in Class 0.2, Class 0.5 and Class 1.0. However, the vibration reed type frequency meter shall be only Class 1.0.
- (4) The receiving indicating meter is represented by the allowable difference against the electrical input volume, and shall be four classes of Class 0.5, Class 1.0, Class 1.5 and Class 2.5.

4. Performance

4.1 Allowable difference The instrument is tested according to 6.2, and the effective measuring range shall be as indicated in Table 1-3. The general allowable difference of the instrument having the dedicated accessory instrument or the quasi-dedicated accessory fixtures shall be the allowable difference of the class displayed in the instrument.

The general allowable difference of the instrument having the general accessory instrument shall be the sum of the allowable difference of the class displayed on the instrument and the accessory fixtures respectively.

The general allowable difference when the class is not displayed on its accessory fixture in the instrument having the general accessory fixture shall be the allowable difference of the class displayed in the instrument.

- (1) Voltmeter, ammeter, wattmeter, reactive-power meter and receiving indicating meter

Table 1

Class	0.2	0.5	1.0	1.5	2.5
Allowable difference %	±0.2	±0.5	±1.0	±1.5	±2.5

- (a) **The instrument which the zero point of the scale is available in the end of the scale** The allowable difference is exhibited by percentage against the maximum scale value.
- (b) **Both swing instrument** The allowable difference is exhibited by percentage against the sum of the upper limit and the lower limit absolute value within the effective measuring range.
- (c) The magnified scale instrument and the scale instrument without zero etc. The allowable difference is exhibited by percentage against the upper limit of the effective measuring range.